

# SM56T

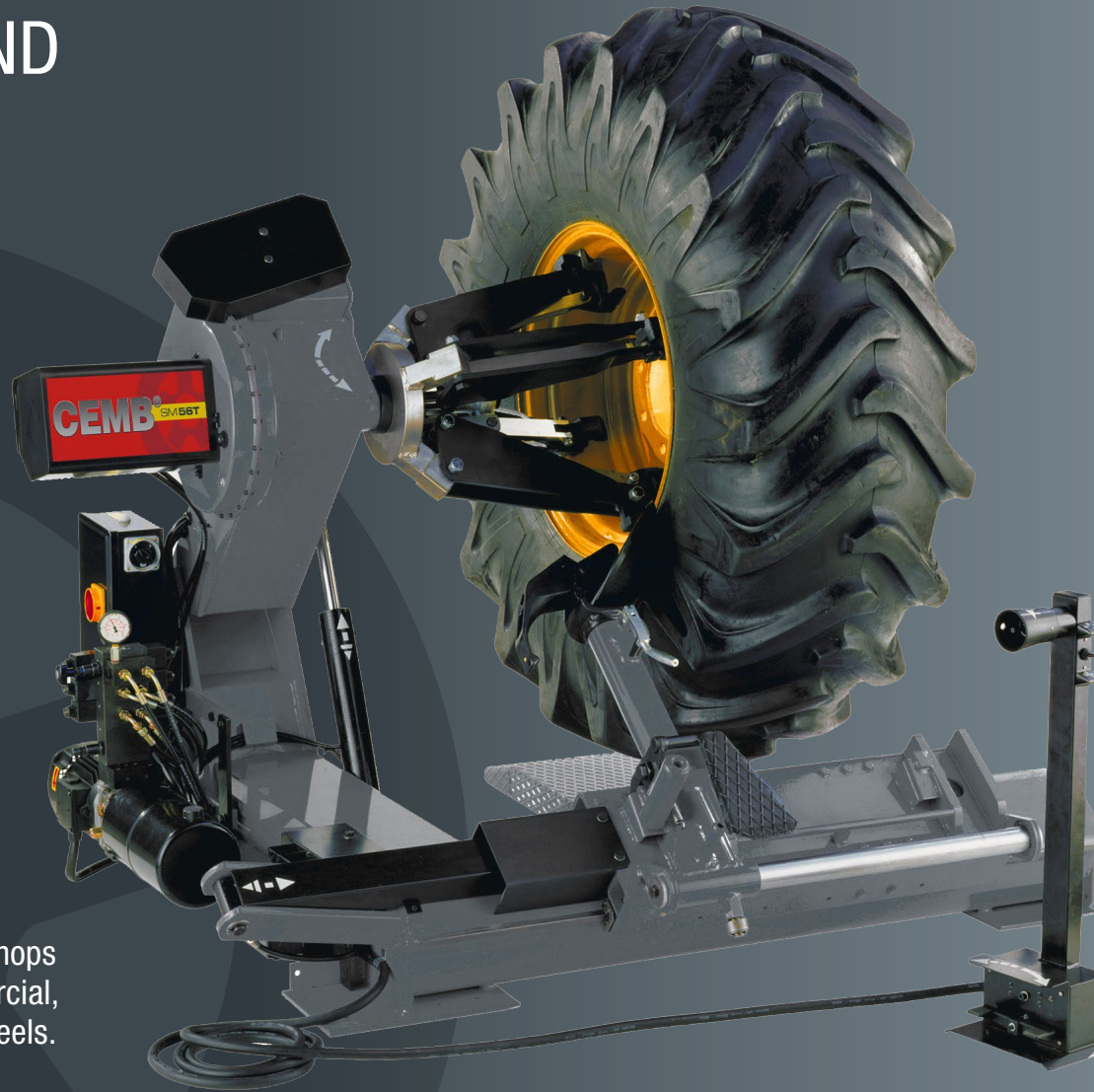

## TRUCK, BUS AND AGRICULTURE TIRE CHANGER



### SM56T TIRE CHANGER

Professional quality unit for tire shops with a heavy workload of commercial, agricultural and earth moving wheels.

**CEMB**<sup>®</sup> **USA**

# SM56T

- Bi-directional rotation
- Two speed motor
- Mobile control unit
- Self-centering universal wheel chuck
- Clamping of rims from 14" to 46"
- Made in ITALY

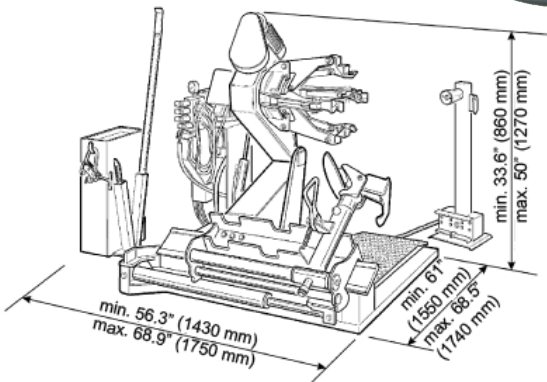

Power requirements	220 VAC, 50/60 Hz, 3 ph
Rim clamping range	14" - 46" (56" with optional extensions)
Max. tire outside	2,300 mm (90.5")
Max. tire width	1,070 mm (42")
Max. tire weight	3,300 lbs (1,500 Kg)
Bead breaker force	6,000 lbs (2,721 Kg)
Operating pressure	130 bar (1,885 psi)
Shipping weight	2,000 lbs (907 Kg)

## STANDARD ACCESSORIES



## OPTIONAL ACCESSORIES

- JAW PROTECTORS - 9234826
- TUBELESS ROLLER - 9299274
- EXTENSIONS KIT (56") - 9235047

- BEAD LIFTING GUIDE LEVER - 9299269
- SCREW CLAMPS - 9299273

# CEMB<sup>®</sup> USA

CEMB<sup>®</sup> USA - BL Systems Inc.  
2873 Ramsey Road, Gainesville GA 30501 - USA  
Phone +1 (678) 717-1050 - sales@cemb-usa.com  
www.cemb-usa.com

DISTRIBUTED BY