

# SM900+



## MOTORCYCLE AND ATV'S TIRE CHANGER

**SM900+ TIRE CHANGER**  
is high volume motorcycle tire changer  
for motorcycle dealers looking to change  
motorcycle, ATV and scooter wheels.



# CEMB<sup>®</sup> USA

# SM900+



■ Press Arm (optional)

■ Clamping of rims from 6" to 24"

■ Can handle wheels up to 9.5" wide

■ Made in Italy

■ Semi-automatic swing arm

■ Inserts protect aluminum wheels

■ Comes fully assembled

■ Dual clamping cylinders

■ Bead breaker designed for motorcycles and ATV's

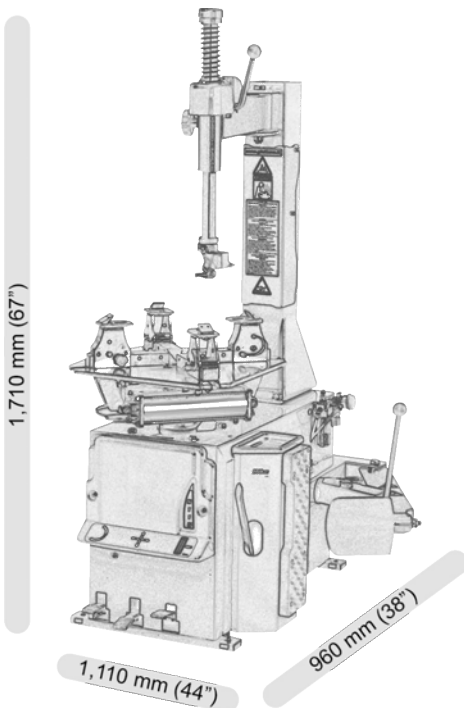

Power requirements	110 VAC, 50/60 Hz, 1 ph
Outside clamping range	6" - 24"
Max. tire outside	1,010 mm (39")
Max. tire width	240 mm (9.5")
Bead breaker force	5,500 lbs (2,517 Kg)
Operating pressure	10 bar (145 psi)
Shipping weight	485 lbs (220 Kg)

## STANDARD ACCESSORIES



## OPTIONAL ACCESSORIES

BEAD PRESSING TOOL - 9208633

DROP CENTER CLAMP - 101159

# CEMB<sup>®</sup> USA

CEMB<sup>®</sup> USA - BL Systems Inc.  
2873 Ramsey Road, Gainesville GA 30501 - USA  
Phone +1 (678) 717-1050 - sales@cemb-usa.com  
www.cemb-usa.com

DISTRIBUTED BY