

**TP9KF**  
**Two-Post Floor Plate Lift**  
(Symmetric)  
**(9,000 lbs. Capacity)**



**ASSEMBLY & OPERATION**  
**INSTRUCTION MANUAL**

July 2015

## **IMPORTANT NOTES**

### **READ THE INSTALLATION AND OPERATION MANUAL IN ITS ENTIRETY BEFORE ATTEMPTING TO INSTALL THE LIFT.**

- Do not install this lift on any surface other than concrete, confirming to minimum specifications.
- Do not install this lift over expansion joints or cracks. Check with building architect.
- Do not install this lift on a second floor with a basement beneath without written authorization from building architect.
- Do not install this lift outdoors unless special consideration has been made to protect the power unit from inclement weather conditions.
- A level floor is recommended for proper installation and operation. Concrete should be a minimum of 4" thickness and 3,000 psi tensile strength with steel or fiber mesh reinforcement.
- The lift is intended to raise the entire body of the vehicle. Do not attempt to lift only part of the vehicle. Improper use of this equipment could result in damage to the lift, yourself or other property.
- The lift is intended to lift vehicles only. It is not designed to lift any person or equipment containing persons.
- Users of this equipment should be qualified, responsible and should follow the operation and safety guidelines set forth in this manual.
- For specifications on concrete pads, please call for technical assistance.
- Improper installation can cause damage or injury. The Manufacturer will NOT assume liability for loss or damage of any kind, expressed or implied, resulting from improper installation to use of this product.

## **DEFINITION**

Surface Mounted, Two-Post, Floor Plate / Open Top Lift, Hydraulic 'chain-over' Drive, 9,000 lbs. Capacity.

The name / model number is designated below:

- *Model number TP9KF - Symmetric Swing Arms configuration*

## **BASIC SPECIFICATIONS**

<b>Model</b>	<b>Description Floor Plate</b>	<b>Capacity</b>	<b>Lifting Time</b>	<b>Overall Height</b>	<b>Overall Width</b>	<b>Lifting height</b>	<b>Between Posts</b>
TP9KF	Symmetric	9000lbs	50 Sec	111-15/16"	141"	72"	110"

## **PREPARATION**

The installation of this lift is relatively simple and can be accomplished by 2 men in a few hours. The following tools and equipment are needed:

- 12 quarts of Non-Detergent / Non-Foaming Hydraulic Oil - SAE-10, AW 32 or equivalent
- Chalk line and 12' Tape Measure
- 4ft. Level
- Rotary Hammer Drill with 3/4" Masonry Drill Bit. (Core Drill Rebar Cutter also recommended)
- Hammer and Hex Key 'Allen' Wrench Set
- Metric Sockets and Open Wrench set - 13mm-30mm
- Medium Crescent Wrench and Medium Pipe Wrench
- Crow Bar for Shim Installation and Medium Flat Screwdriver
- Vise Grips, Needle Nose and Snap Ring Pliers

## **GENERAL INFORMATION**

1. Carefully remove the crating and packing materials.

**CAUTION!** *Be careful when cutting steel banding material as items may become loose and fall causing personal harm or injury.*

2. Identify the components and check for damage or shortages.

**Please contact your distributor immediately, if any damages or shortages are discovered.**

### **Packing:**

- \* The lift assembly is packaged into two columns as one piece, as shown in **(Fig.1)**.
- \* Every column comes with its cylinder, carriage, cables & chains, upright, lifting arms, pad with holders, hoses and drive-over base plate with the hardware box located in one of the columns.
- \* The electric-hydraulic motor pump is packaged separately and banded to lift – (not shown).



**Fig. 1**

## FOUNDATION and ANCHORING REQUIREMENTS

1. Concrete shall have compression strength of at least 3,000 PSI and a minimum thickness of 4" in order to achieve a minimum anchor embedment of 3-1/4". NOTE: When using the standard supplied 3/4" x 5-1/2" long anchors, if the top of the anchor exceeds 2-1/4" above the floor grade, you DO NOT have enough embedment.
2. Maintain a 6" minimum distance from any slab edge or seam. Hole to hole spacing should be a minimum 6-1/2" in any direction. Hole depth should be a minimum of 4".
3. DO NOT install on asphalt or other similar unstable surface. Columns are supported only by anchoring to floor.
4. Using the horseshoe shims provided, shim each column base as required until each column is plumb. If one column has to be elevated to match the plane of the other column, full size base shim plates should be used. Torque anchors to 130 ft-lbs. Shim thickness MUST NOT exceed 1/2" when using the 5-1/2" long anchors provided with the lift.
5. If anchors do not tighten to 130 ft-lbs. installation torque, replace the concrete under each column base with a 4' x 4' x 6" thick 3,000 PSI minimum concrete pad keyed under and flush with the top of existing floor. Allow concrete to cure before installing lifts and anchors (typically 2 to 3 weeks).

## ANCHORING TIPS

1. Use a concrete hammer drill with a carbide tip, solid drill bit the same diameter as the anchor, 3/4" - (.775 to .787 inches diameter). Do not use excessively worn bits or bits which have been incorrectly sharpened.
2. Keep the drill in a perpendicular line while drilling.
3. Let the drill do the work. Do not apply excessive pressure. Lift the drill up and down occasionally to remove residue to reduce binding.
4. Drill the hole to depth of 2" deeper than the length of anchor. NOTE: Drilling thru concrete (recommended) will allow the anchor to be driven thru the bottom of foundation if the threads are damaged or if the lift will need to be relocated.
5. For better holding power blow dust from the hole.
6. Place a flat washer and hex nut over threaded end of anchor, leaving the nut almost flush with the top of the anchor bolt. Carefully tap anchor into hole. Do not damage threads. Tap anchor into the concrete until nut and flat washer are against base plate. Do not use an impact wrench to tighten! Tighten the nut, two or three turns on average after the concrete has cured (28-day cure). If the concrete is very hard only one or two turns may be required.

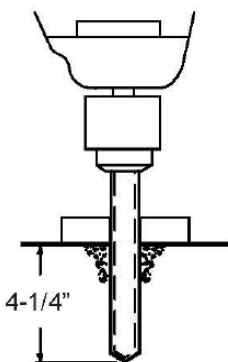

Drill holes using 3/4" carbide tipped masonry drill bit per ANSI standard B94.12.1977

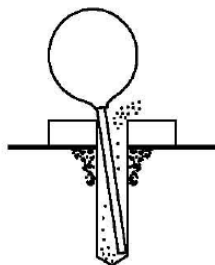

Clean hole.

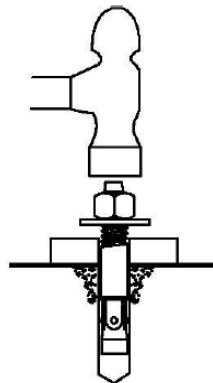

Run nut down just below impact section of bolt. Drive anchor into hole until nut and washer contact base.

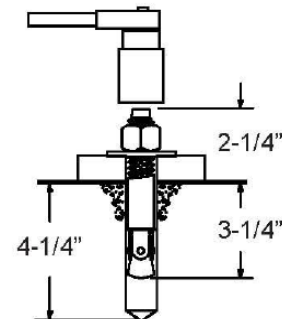

Tighten nut with Torque wrench to 130 ft.-lbs.

# INSTALLATION INSTRUCTIONS

**STEP 1:** (Selecting Site) Before installing your new lift, check the following:

1. **LIFT LOCATION:** Always use architects plans when available. Check layout dimension against floor plan requirements making sure that adequate space is available (**Fig. 2 & Fig. 3**).

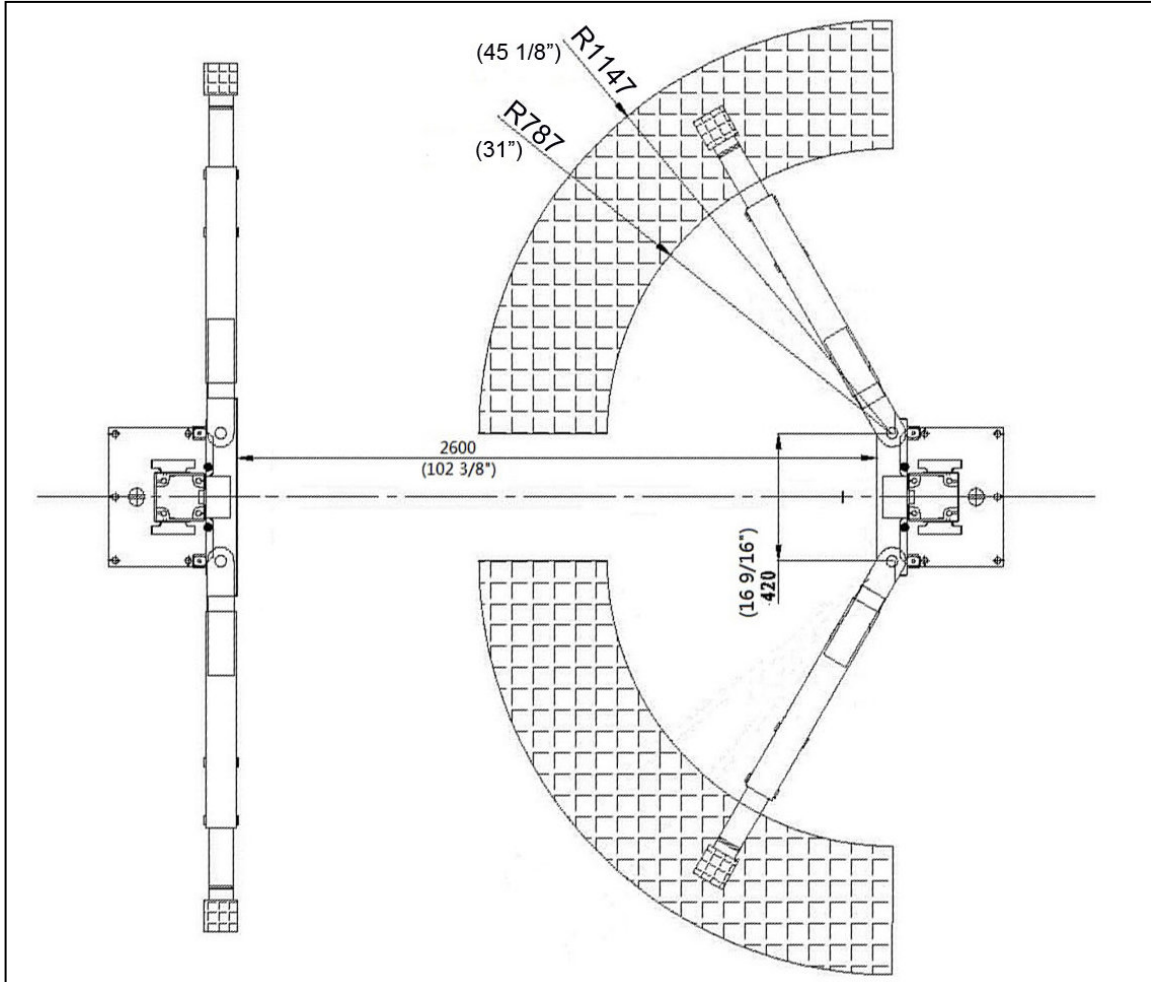

**Fig. 2**  
(TP9KF - Symmetric Lift)

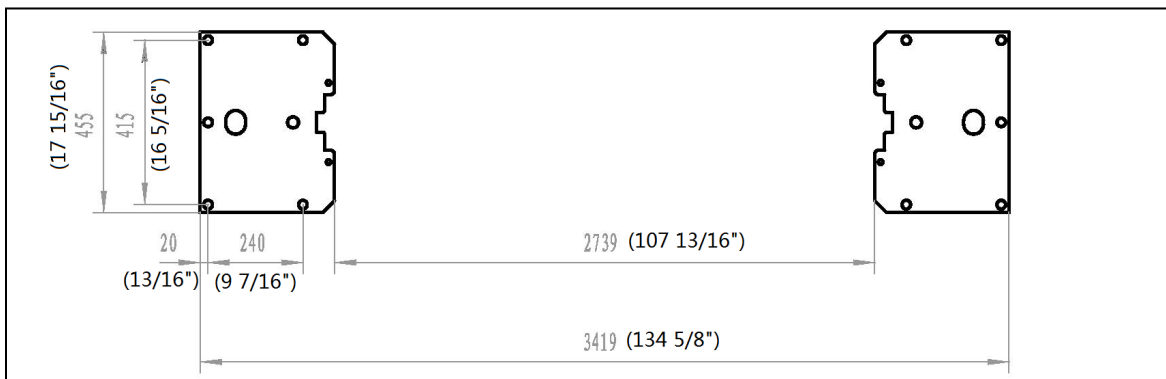

**Fig. 3**  
(Column / Floor Layout)

2. OVERHEAD OBSTRUCTIONS: The area where the lift located should be free of overhead obstructions such as heaters, building supports, electrical lines etc (Fig. 4).

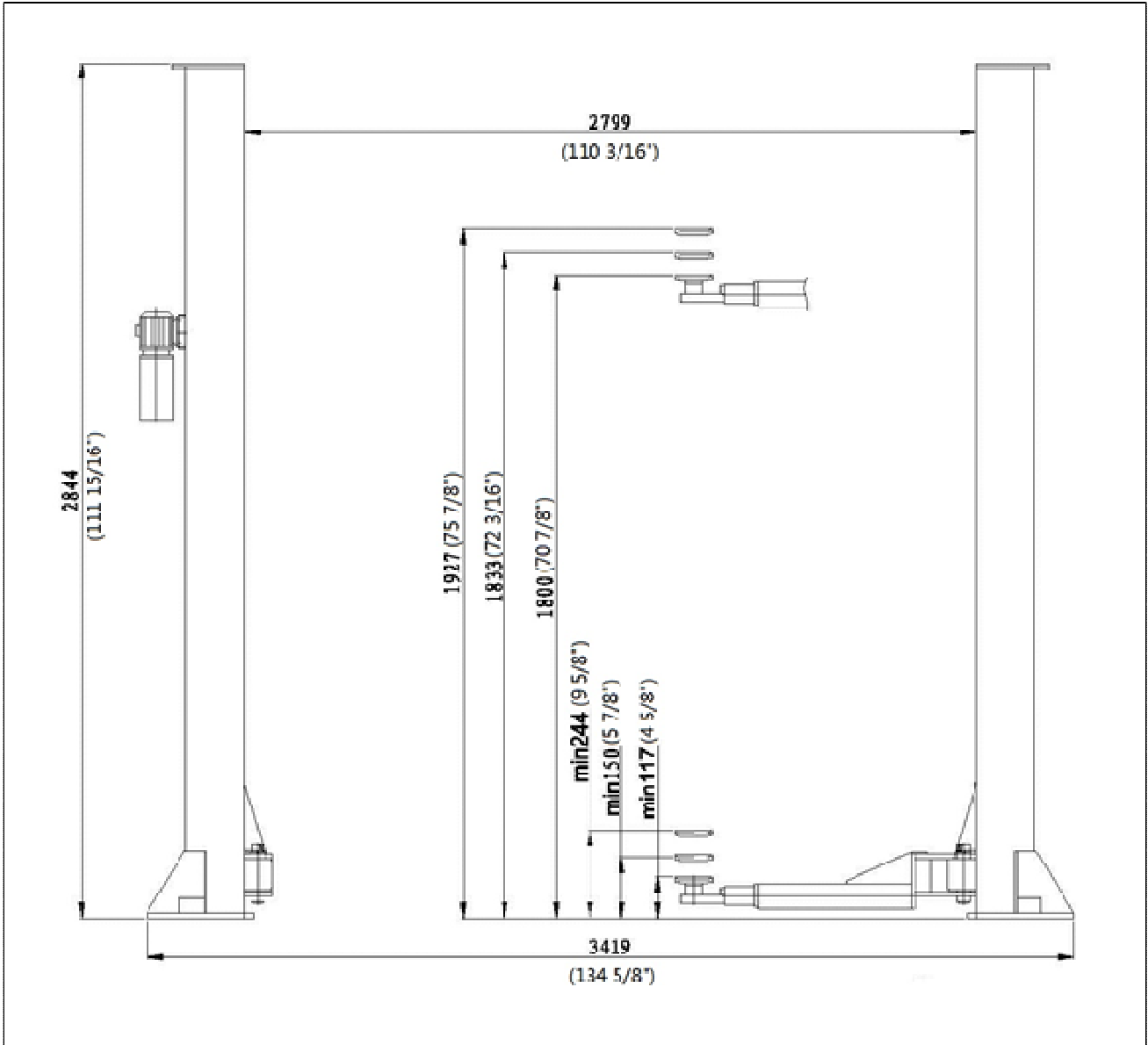

Fig. 4

3. DEFECTIVE CONCRETE: Visually inspect the site where the lifts will be installed and check for cracked or defective concrete. (Details on Page 4)
4. FLOOR REQUIREMENTS: The lift should be installed on a 3000 PSI concrete with minimum of 4" thickness. The Floor should be level with-in gradients of  $\leq 1/4"$  within area of the two columns = 135" x 18").

**(See Details for Foundation Anchoring Requirements & Anchoring Tips on Page 4)**

**STEP 2:** (Unloading and Unpacking)

1. After unloading the lift, place it near the intended installation location.
2. Remove the shipping bands and packing materials from the unit.
3. Remove the packing brackets and bolts holding the two columns together. (Do not discard bolts, they may be used in the assembling of the lift )
4. Take out the up-rights, lifting arms, pads, accessory box, hoses, etc, from the column. Check the quantity of every item with the parts list. If any missing, please contact with your dealer at once.

**STEP 3:** (Site Layout)

1. Determine which side will be the approach side.
2. Now determine which side you prefer the power unit to be located on. The MAIN column has the power-unit mounting bracket attached to the side (**Fig. 5**).  
*Note: the power unit column can be located on either side. It is helpful to try and locate the power side on the driver side of the vehicle when loaded on the lift, in order to save steps during operation.*
3. Once a location is determined, use a carpenter's chalk line to layout a grid for the post locations. (**See Fig. 3**)



**Fig. 5**

4. After the post locations are marked, use a chalk or crayon to make an outline of the posts on the floor at each location using the post base plates as a template.
5. Double check all dimensions and make sure that the layout is perfectly square.

**STEP 4:** (Installing the MAINSIDE Column)

1. Before proceeding, double check measurements and make certain that the bases of each column are square and aligned with the chalk line.
2. Assemble the top plate to the column. Raise the column to a vertical position (See Fig.6 )



**Fig. 6**

3. Using the base plate on the MAINSIDE column as a guide, drill each anchor hole in the concrete approximately 5½” deep using a rotary hammer drill and ¾” concrete drill-bit. To assure full holding power, do not ream the hole or allow the drill to wobble. **(See Anchoring Details on Page 4)**
4. After drilling, remove dust thoroughly from each hole using compressed air and/or wire brush. Make certain that the column remains aligned with the chalk line during this process.
5. Assemble the washers and nuts on the anchors then tap into each hole with a block of wood or rubber hammer until the washer rests against the base plate. Be sure that if shimming is required that enough threads are left exposed.
6. Using a level, check column plumb for every side **(Fig. 8)**. If shimming is required, use 3/4” washers or shim stock, placing shims as close as possible to the hole locations. This will prevent bending the column base plates.
7. With the shims and anchor bolts in place, tighten by securing the nut to the base then turning 2-3 full turns clockwise. Or tighten anchor bolts to 130 ft-lbs. of torque. DO NOT use an impact wrench for this procedure.

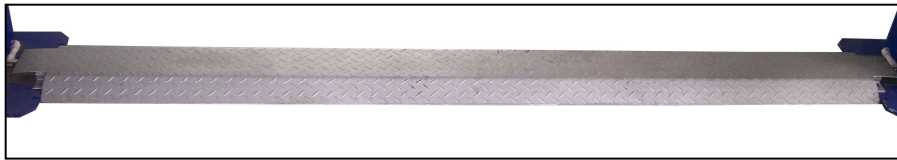

**Fig. 9**



**Fig. 8**

**STEP 5:** (Mounting the OFFSIDE Column and the Drive-Over Base Plate)

1. Position the OFFSIDE column at the designated chalk locations.
2. Using the Drive-Over Base Plate bolts provided, make sure that the distance between the two columns is correct **(Fig.9)**.
3. Using a tape measure to measure the distance between the opposite corners of the base plate on the columns. Equal values will ensure the lifting arms will be square.

*Note: Test fitting the Drive-Over Base is recommended to ensure proper column spacing, alignment & fit.*

4. Set Drive-Over Base Plate aside, it is to be mounted after hose & cable installations in STEPS 7 & 8.
5. Secure OFFSIDE column to the floor following the same procedures as outlined in **STEP 4**.



**STEP 6:** (Mounting the POWER UNIT)

1. Attach the power unit to the POWERSIDE COLUMN using bolts, nuts and washers supplied (Fig. 10).
2. Remove the vent plug from the power unit and fill the reservoir with hydraulic oil. Make sure the funnel used to fill the power unit is clean.

Suggestion: Use AW 32, or 46 Non-Detergent Non-Foaming Anti-Wear Hydraulic Oil SAE-10 (Texaco HD46 or equal). The unit will hold approximately ten quarts of fluid.



**Fig. 10**

**STEP 7:** (Routing the EQUALIZER CABLES)

1. Raise and lock each carriage on the first safety latch engagement. It is approximately 30" high.
2. Make sure that the safety locks on each column are fully engaged before attempting to route equalizer cables.
3. Be sure each carriage is at the same height by measuring from the top of the base to the bottom of the carriage. This difference should be within 1/4".
4. Route the first cable. **(See Figs. 11-13)** Screw the nut on the cable stud so that half thread pass through the nut. Pull the other end of the cable and screw the nut on it also. Then tighten both nuts.

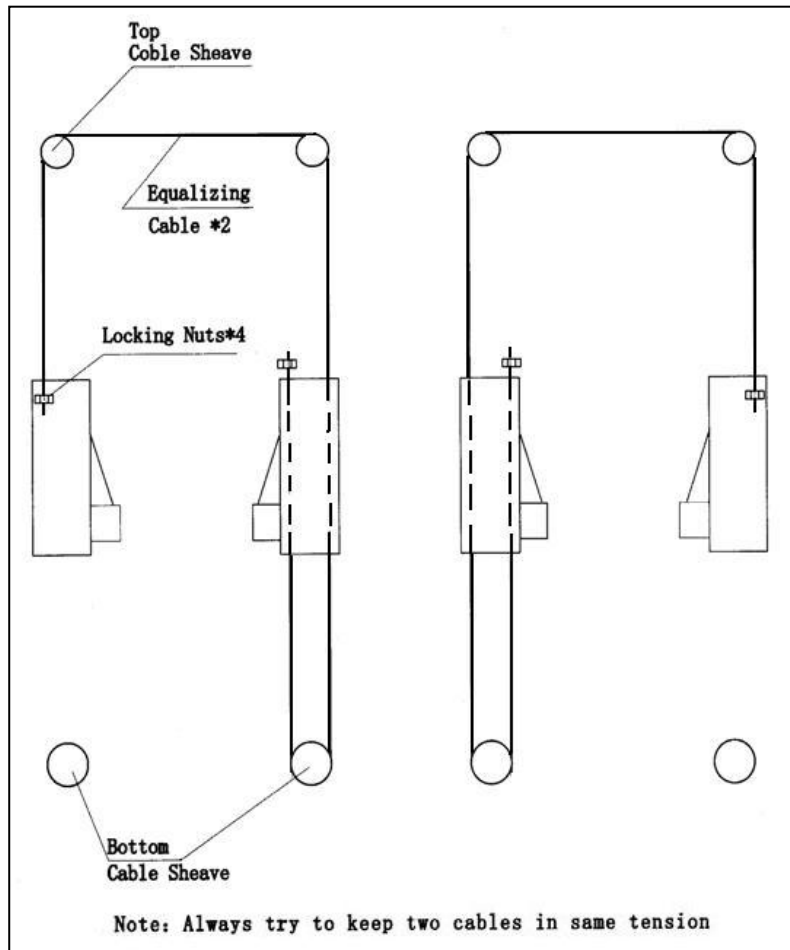

**Fig. 11**



**Fig. 12**

## Cable Route Diagram



**Fig. 13**

5. Repeat above for the second cable.
6. Adjust each equalizer cable to approximately 1/2" side-to-side play. Ensure that each cable has equal tension. Also, check the carriage height to ensure both carriages are sitting on the same latch.

### **STEP 8:** (Connecting the Hydraulic Hoses)

As shown on **Figs. 12 & 14-16**, connect the hydraulic hoses.

When routing the hydraulic hose, make sure that the hose is clear of any moving parts. It is necessary to route hose through the retaining rings or tie hose clear by using nylon tie straps or wire.



**Fig. 14**

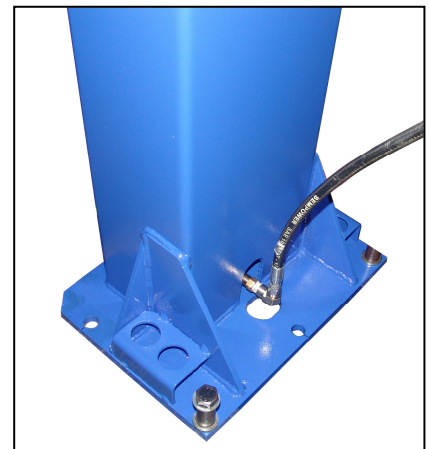

**Fig. 15**

## Hose Route Diagram

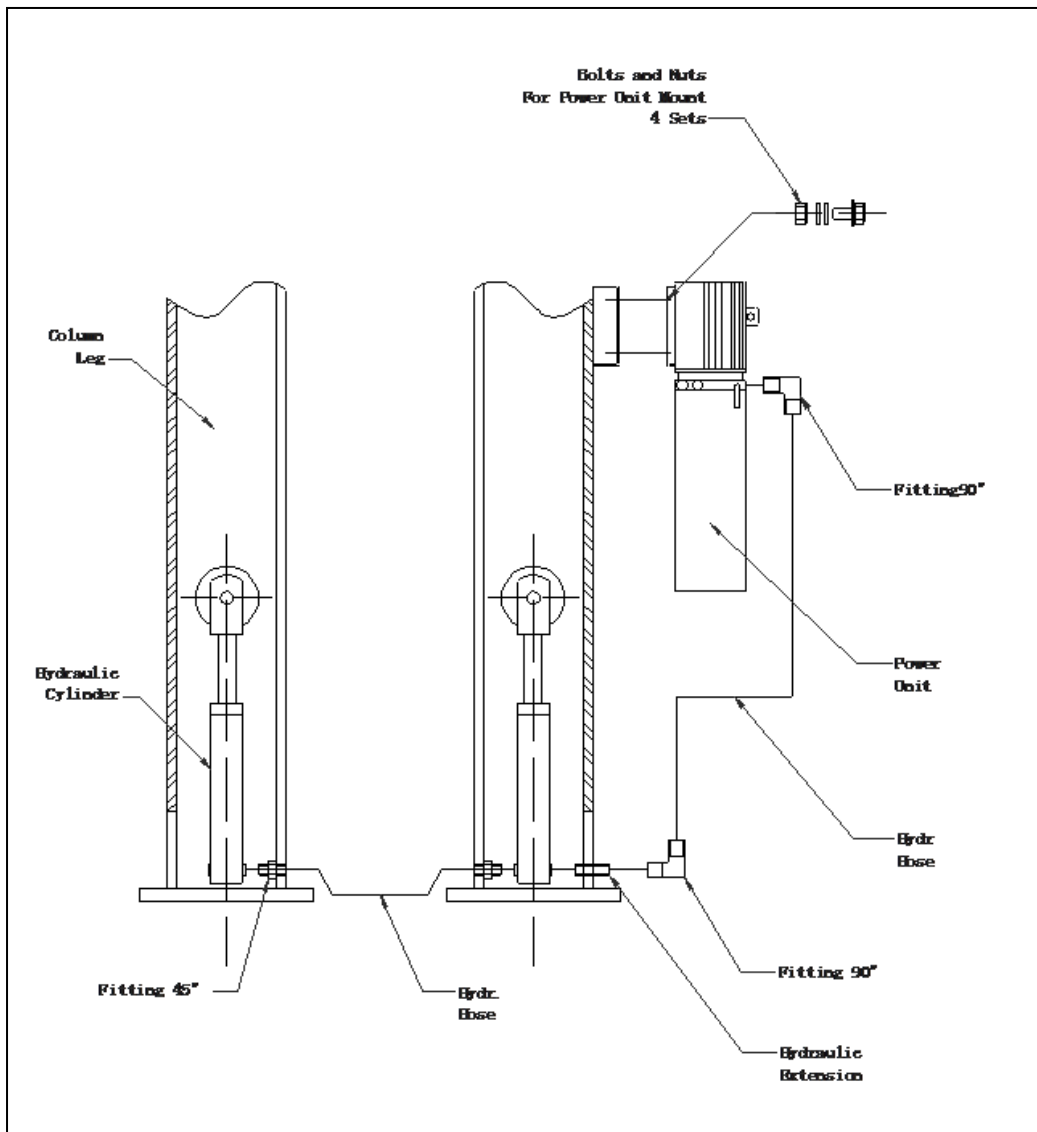

Fig. 16

### **STEP 9:** (Installing Lifting Arms & Arm Restraints)

Install the lifting swing arms on the carriages using the included 1-1/2" diameter pins. Check for proper engagement of the arm restraint. The rack on the arm restraints should fully engage the gear on the arm (Figs. 17-19).



Fig.17

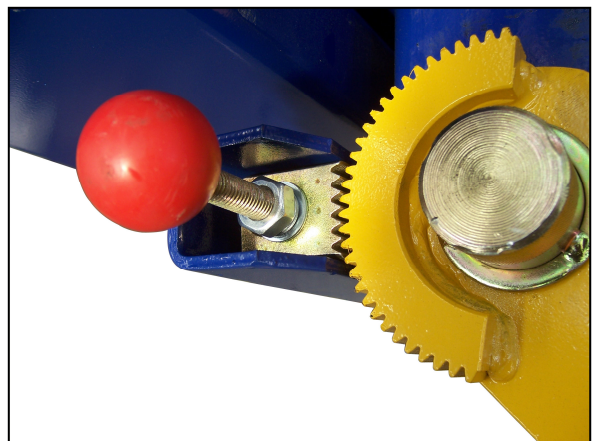
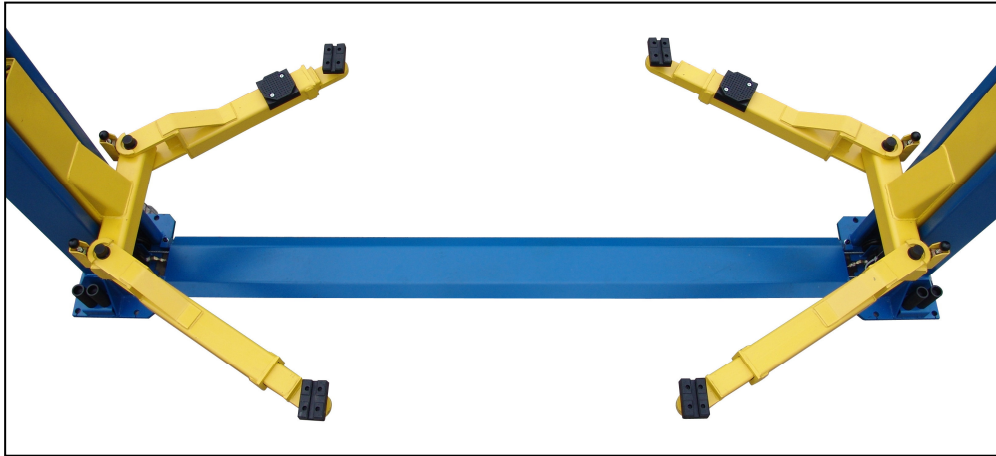

Fig. 18

**STEP 10:** Mount Drive-Over Base Plate at this time, using bolts provided (Fig 9 & 19).



**Fig. 19**

**STEP 11:** (Electrical connection)

Make the Electrical hookup to the power unit (220V Single Phase).

***Important:*** the wiring must comply with local code. Have a certified electrician make the electrical hook-up to the power unit. Use separate circuit for each power unit. Protect each circuit with time delay fuse or circuit breaker. For 208V-230V single phase, use 20 amp fuse.

***Warning:*** Never operate the motor in line voltage less than 208V. Motor damage may occur. Also, Motor cannot run on 50hz without a physical change to motor.

**STEP 12:** (Checking running)

Do not place any vehicle on the lift at this moment. Cycle the lift up and down several times to ensure latches click together and all air is removed from the hydraulic system. To lower the lift, both latch releases must be manually released (**Fig. 20**). Latches will automatically reset once the lift ascends approximately 17 " from base. If latches click out of sync, tighten the equalization cable on the one that clicks first.

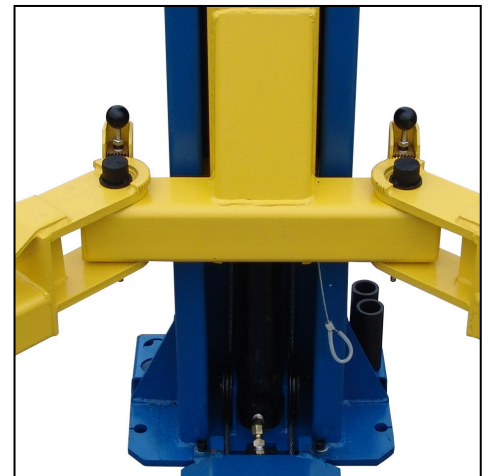

**Fig. 20**

**THE LIFT IS NOW READY FOR USE.**

## PERFORMANCE

### RAISE LIFT

1. Read operating and safety manuals before using lift.
2. Always lift a vehicle according to the manufacturers recommended lifting points
3. Position vehicle between columns.
4. Adjust swing arms so that the vehicle is positioned with the center of gravity midway between pads.
5. Use truck adapters as needed. Never exceed 9" of pad height.
6. Raise the lift by pressing button on power unit until support contacts underside of the vehicle. Recheck to make sure vehicle is secure.
7. Raise vehicle to desired working height. The latch mechanism will 'trip over' when the lift raises and drop into each latch stop. But, to lock the lift you must press the Lower level to relieve the hydraulic pressure and let the latch set tight in a safety position.

*Always lock the lift before going under the vehicle. Never allow anyone to go under the lift when raising or lowering. Read the safety procedures in the manual.*

Note: It is normal for an empty lift to lower slowly-it may be necessary to add weight.

### LOWER LIFT

1. Be sure tool trays , stands or personal are removed from under vehicle.
2. First to raise the lift until the latch clears.
3. Pull latch release cables on both sides

**WARNING:** ALWAYS RELEASE BOTH SIDES

4. Press the lever at the power unit to lower the lift.
5. Before removing vehicle from lift area, position lift arms and supports to provide an unobstructed exit.

**WARNING:** NEVER DRIVE OVER LIFT ARMS

## **SAFETY PROCEDURES**

- Never allow unauthorized persons to operate lift. Thoroughly train new employees in the operation and care of lift.
- Caution: the power unit operates at high pressure.
- Remove passengers before raising vehicle.
- Prohibit unauthorized persons from being in shop area while lift is in use.
- Total lift capacity is 9000Lbs with 2250lbs per arm pad. Never exceed the capacity.
- When approaching the lift with a vehicle, center the vehicle between the columns so that the tires will clear the swing arms easily. Slowly drive the vehicle up between the posts. Have some one outside the vehicle guide the driver.
- Always lift vehicle using all four arms. Never use lift to raise one end or one side of vehicle.
- Prior to lifting vehicle, walk around the lift and check for any objects that might interfere with the operation of lift and safety latches; tools, air hoses, shop equipment.
- Raise vehicles about 3" and check stability by rocking.
- Prior to lowering vehicle, walk around the lift and check for any objects that might interfere with the operation of lift and safety latches; tools, air hoses, shop equipment. Swing the arms out of the path and slowly drive the vehicle out. Have some one outside the vehicle guide the driver.

**ALWAYS LOCK THE LIFT BEFORE GOING UNDER THE VEHICLE.**

**NEVER ALLOW ANYONE TO GO UNDER THE LIFT WHEN RAISING OR LOWERING.**

## **MAINTENANCE SCHEDULE**

The following periodic maintenance is the suggested minimum requirements and minimum intervals; accumulated hours or monthly period, whichever ever comes sooner. If you hear a noise or see any indication of impending failure - **cease operation immediately** – inspect, correct and / or replace parts as required.

**WARNING OSHA AND ANSI REQUIRE USERS TO INSPECT LIFTING EQUIPMENT AT THE START OF EVERY SHIFT. THESE AND OTHER PERIODIC INSPECTIONS ARE THE RESPONSIBILITY OF THE USER.**

### **DAILY PRE-OPERATION CHECK (8 HOURS)**

The user should perform daily check. ATTENTION! LOOK OUT! Daily check of safety latch system is very important-the discovery of device failure before needed could save you from expensive property damage, lost production time, serious personal injury and even death.

- Check safety lock audibly and visually while in operation
- Check safety latches for free movement and **full engagement with rack.**
- Check hydraulic connections, and hoses for leakage.
- Check cables connections- bends, cracks-and looseness
- Check for frayed cables in both raised and lowered position.
- Check snap rings at all rollers and sheaves.
- Check anchors, bolts, nut, and screws and tighten them.
- Check wiring & switches for damage.
- Keep base plate free of dirt, grease or any other corrosive substances.
- Check floor for stress cracks near anchor bolts.
- Check swing arm restraints.

### **WEEKLY MAINTENANCE (40 HOURS)**

- Check anchor bolts torque to 11 Kg\*m for the 18mm anchor bolts. *Do not use impact wrench.*
- Check floor for stress cracks near anchor bolts.
- Check hydraulic oil level.
- Check and tighten bolts and nuts, and screws.
- Check cylinder for free movement.
- Check cable pulley for free movement and excessive wear.

## **YEARLY MAINTENANCE**

- Grease rub blocks and column surface contacting rub blocks
- Change the hydraulic fluid. Good maintenance procedure makes it mandatory to keep hydraulic fluid clean. No hard fast rules can be established;-operating temperature, type of service, contamination levels, filtration, and chemical composition of fluid should be considered. If operating in dusty environment shorter interval may be required.

### **Only a trained maintenance expert should perform the following items.**

- Replace hydraulic hoses
- Replace chains and rollers.
- Replace cables and sheaves.
- Replace or rebuild air and hydraulic cylinders as required.
- Replace or rebuild pumps / motors as required.
- Check hydraulic and air cylinder rod and rod end (threads) for deformation or damage.
- Check cylinder mount for looseness and damage.

**Relocating or changing components may cause problems. Each component in the system must be compatible; an undersized or restricted line will cause a drop in pressure. All valve, pump, and hose connections should be sealed and / or capped until just prior to use. Air hoses can be used to clean fittings and other components. However, the air supply must be filtered and dry to prevent contamination. Contamination is the most frequent cause of malfunction or hydraulic equipment.**



# TROUBLE SHOOTING

## **1. Motor does not run:**

- A. Breaker or fuse blown
- B. Faulty wiring connections. Call electrician.
- C. Defective up button. Call electrician for checking.
- D. Defective Capacitor. Call electrician for checking.

## **2. Motor runs but will not raise:**

- A. Oil level too low. Oil level should be just under the vent cap port when the lift is down!!!
- B. Check the clearance in the plunger valve of the lowering handle.
- C. Remove the check valve cover and clean ball and seat.
- D. A piece of trash is under check valve. Push handle down and push the up button at the same time. Hold for 10-15 seconds. This should flush the system.

## **3. Oil blows out breather of power unit:**

- A. Oil reservoir overfilled.
- B. Lift lowered too quickly while under a heavy load.

## **4. Motor hums and will not run:**

- A. Lift overloaded--- remove excessive weight from lift
- B. Bad capacitor-----call electrician
- C. Low voltage-----call electrician
- D. Faulty wiring-----call electrician

## **5. Lift jerks going up and down:**

- A. Air in hydraulic system-----Raise lift all the way to top and return to floor. Repeat 4-6 times with interval at least 2 min. Ensure to NOT overheat power unit.

## **6. Oil leaks**

- A. Power unit-----If the power unit leaks hydraulic oil around the tank-mounting flange, check the oil level in the tank. The level should be two inches below the flange of the tank. Check with a screwdriver.
- B. Rod end of cylinder-----The rod seal of the cylinder is out. Rebuild or replace the cylinder.
- C. Breather end of the cylinder-----the piston seal of the cylinder is out. Rebuild or replace the cylinder.

## 7. Lift makes excessive noise.

- A. Carriage of the lift is dry and requires grease. Grease corners of columns.
- B. Cylinder pulley assembly or cable pulley assembly is not moving freely. Check and grease it.
- C. May have excessive wear on pins or cylinder yoke. Check and replace them.
- D. Seals are dry in hydraulic Cylinder(s).

**IMPORTANT**

POWER UNIT PRIMING PROCEDURE

**THE PROBLEM: Power unit runs fine but will not pump any fluid.**

Step 1 – Locate the check valve, the flush plug to the left of the lowering valve.  
(See drawing below.)

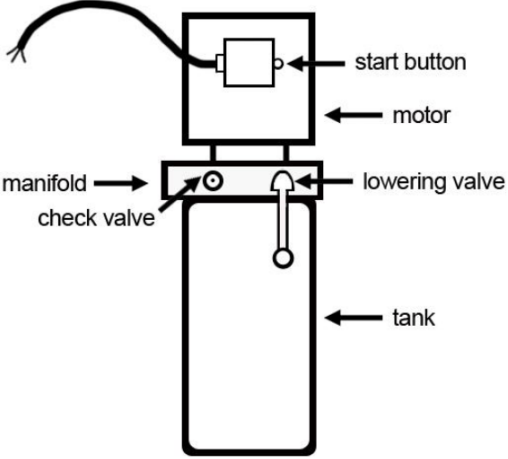

Step 2 – Using an Allen wrench and shop towel – with shop towel in place to catch fluid – loosen the check valve plug 2 ½ turns to allow it to leak.

Step 3 – Push the START button for one second, then release for three seconds.  
Repeat these steps until unit starts pumping fluid.

Step 4 – Tighten the check valve plug.

**YOUR POWER UNIT SHOULD BE PRIMED**

## OWNER / EMPLOYER RESPONSIBILITIES

The Owner / Employer:

- Shall establish procedures to periodically maintain, inspect and care for the lift in accordance with the manufactures recommended procedures to ensure its' continued safe operations.
- Shall provide necessary lockout of energy sources per ANSIZ244.1 –1982 before beginning any lift repairs.
- Shall not modify the lift in any manner without prior written consent of the manufacture.

# PARTS DRAWING

Fig. A-1

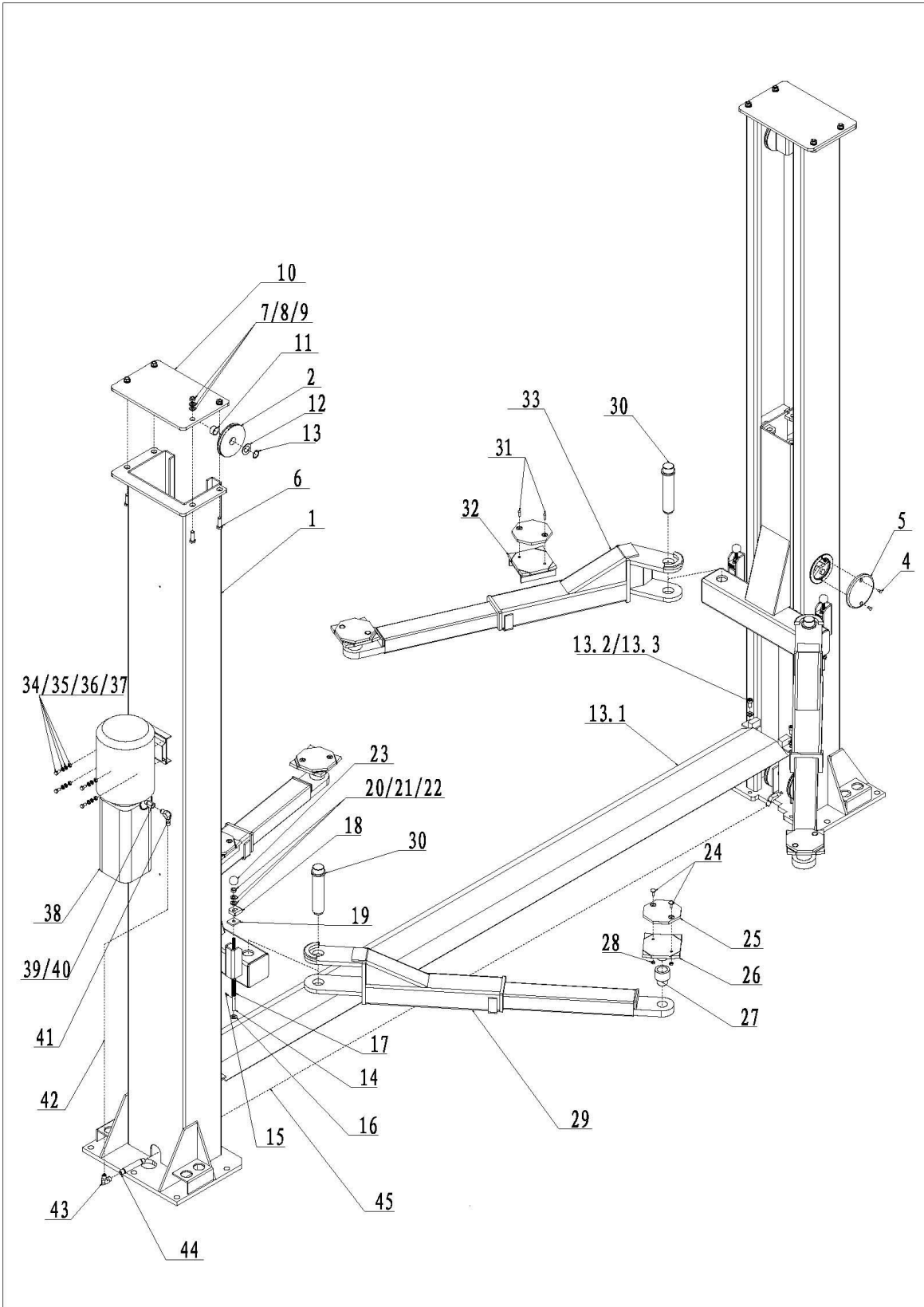

# PARTS DRAWING

Fig. A-2

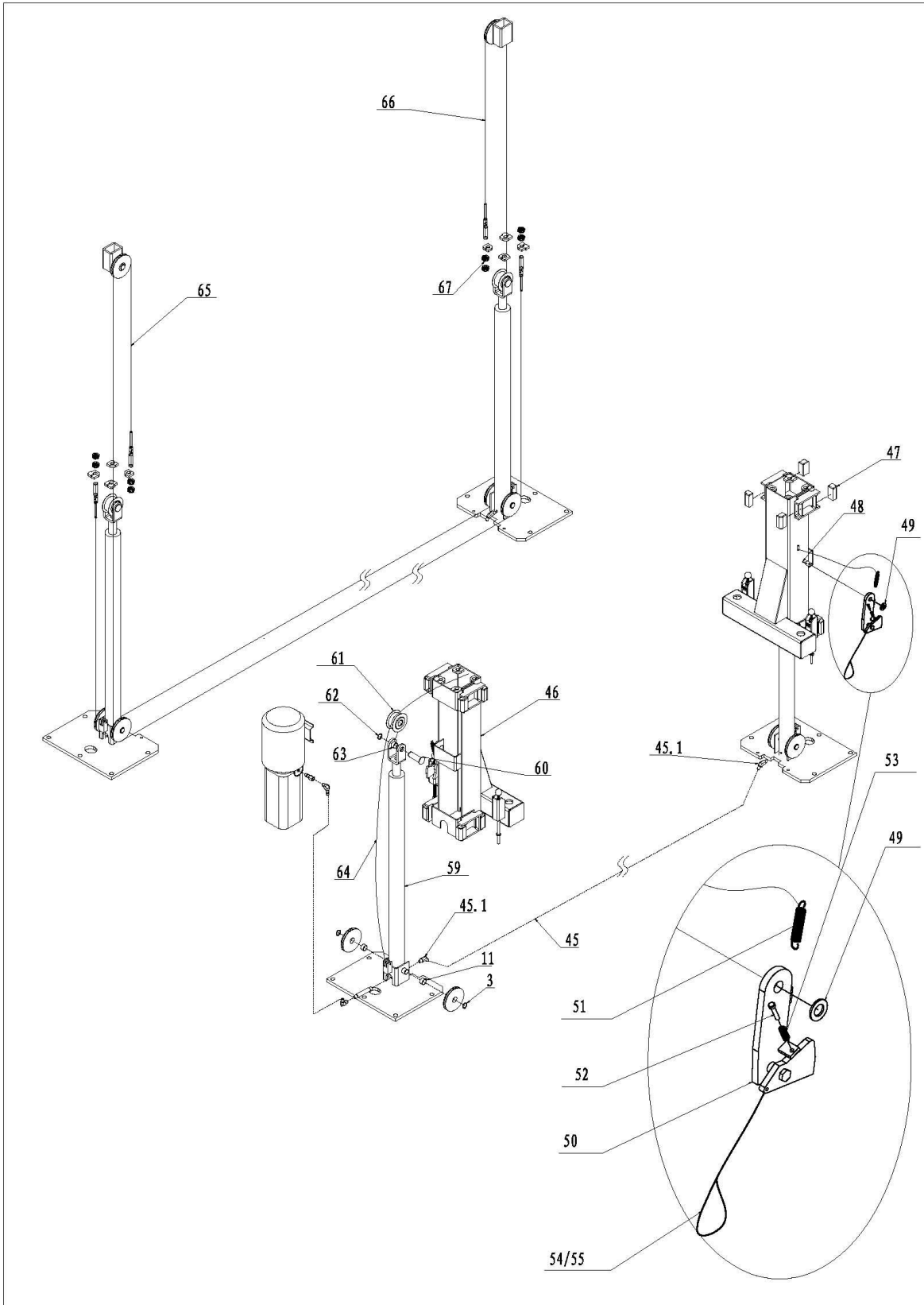

## PARTS LIST

ITEM	DESCRIPTION	QTY
1	Column jointing (L,R)	2
2	Pulley	6
3	Spindle spring washer	6
4	Cover	2
5	Cross bolt	4
6	Hex bolt C	8
7	Nut	8
8	Flat washer	8
9	Spring washer	8
10	Top plate	2
11	Bushing	6
12	Flat washer C	2
13	Spindle spring washer A	2
13.1	Drive-Over Base Plate	1
13.2	Inner Hex bolt	4
13.3	Flat washer	4
14	Rack spindle	4
15	Shaft sheath	4
16	Flat washer A	4
17	Spring	4
18	Rack board	4
19	Ramp board	4
20	Nut	4
21	Flat washer	4
22	Spring washer	4
23	Ball handle	4
24	Bolt	8
25	Rubber pad	4
26	Pad weldment	4
27	Low adaptor	4
27.1	High adaptor	4
28	Nut	8

<b>ITEM</b>	<b>DESCRIPTION</b>	<b>QTY</b>
29	Symm Swing arms L	2
30	Arm pin	4
31	Cross bolt	4
32	Saddle pad weldment	2
33	Symm Swing arm R	2
34	Hex bolt C	4
35	Nut	4
36	Flat washer	4
37	Spring washer	4
38	Power unit	1
39	Washer	1
40	Hydraulic fitting	1
41	Elbow fitting	1
42	Hydraulic hose, short	1
43	Elbow fitting	1
44	Pipe nipple	1
45	Hydraulic Hose, long	1
45.1	Hydraulic fitting, 45 degree	2
46	Carriage	2
47	Nylon block	16
48	Shaft sheath	2
49	Flat washer	2
50	Safety Latch	2
51	Pull Spring	2
52	Inner hex bolt	2
53	Spring	2
54	Pull wire	2
55	Plastic sheath	2
59	Hydraulic cylinder	2
60	Spindle	2
61	Idler wheel	2
62	Spindle spring washer	2

<b>ITEM</b>	<b>DESCRIPTION</b>	<b>QTY</b>
63	Spindle	4
64	Chain	2
65	Steel cable	1
66	Steel cable	1
67	Nut	8

# TUXEDO DISTRIBUTORS LIMITED WARRANTY

## **Structural Warranty:**

The following parts and structural components carry a five year warranty:

Columns	Arms	Uprights	Swivel Pins
Legs	Carriages	Overhead Beam	
Tracks	Cross Rails	Top Rail Beam	

## **Limited One-Year Warranty:**

Tuxedo Distributors, LLC ("Tuxedo") offers a limited one-year warranty to the original purchaser of Tuxedo Lifts and Wheel Service in the United States and Canada. Tuxedo will replace, without charge, any part found defective in materials or workmanship under normal use, for a period of one year after purchase. The purchaser is responsible for all shipping charges. This warranty does not apply to equipment that has been improperly installed or altered or that has not been operated or maintained according to specifications.

## **Other Limitations:**

This warranty does not cover:

1. Parts needed for normal maintenance
2. Wear parts, including but not limited to cables, slider blocks, chains, rubber pads and pulleys
3. Replacement of lift and tire changer cylinders after the first 30 days. A seal kit and installation instructions will be sent for repairs thereafter.
4. On-site labor

Upon receipt, the customer must visually inspect the equipment for any potential freight damage before signing clear on the shipping receipt. Freight damage is not considered a warranty issue and therefore must be noted for any potential recovery with the shipping company.

The customer is required to notify Tuxedo of any missing parts within 72 hours. Timely notification must be received to be covered under warranty.

Tuxedo will replace any defective part under warranty at no charge as soon as such parts become available from the manufacturer. No guarantee is given as to the immediate availability of replacement parts.

Tuxedo reserves the right to make improvements and/or design changes to its lifts without any obligation to previously sold, assembled or fabricated equipment.

There is no other express warranty on the Tuxedo lifts and this warranty is exclusive of and in lieu of all other warranties, expressed or implied, including all warranties of merchantability and fitness for a particular purpose.

To the fullest extent allowed by law, Tuxedo shall not be liable for loss of use, cost of cover, lost profits, inconvenience, lost time, commercial loss or other incidental or consequential damages.

This Limited Warranty is granted to the original purchaser only and is not transferable or assignable.

Some states do not allow exclusion or limitation of consequential damages or how long an implied warranty lasts, so the above limitations and exclusions may not apply. This warranty gives you specific legal rights and you may have other rights, which may vary from state to state.

1905 N Main St Suite C, Cleburne, TX 76033  
Ph 817-558-9337 Fax 817-558-9740