

Instructions for ESCAPE[™] ETM



Please read before use.



Register your product
at <http://www.mytee.com/support/register>

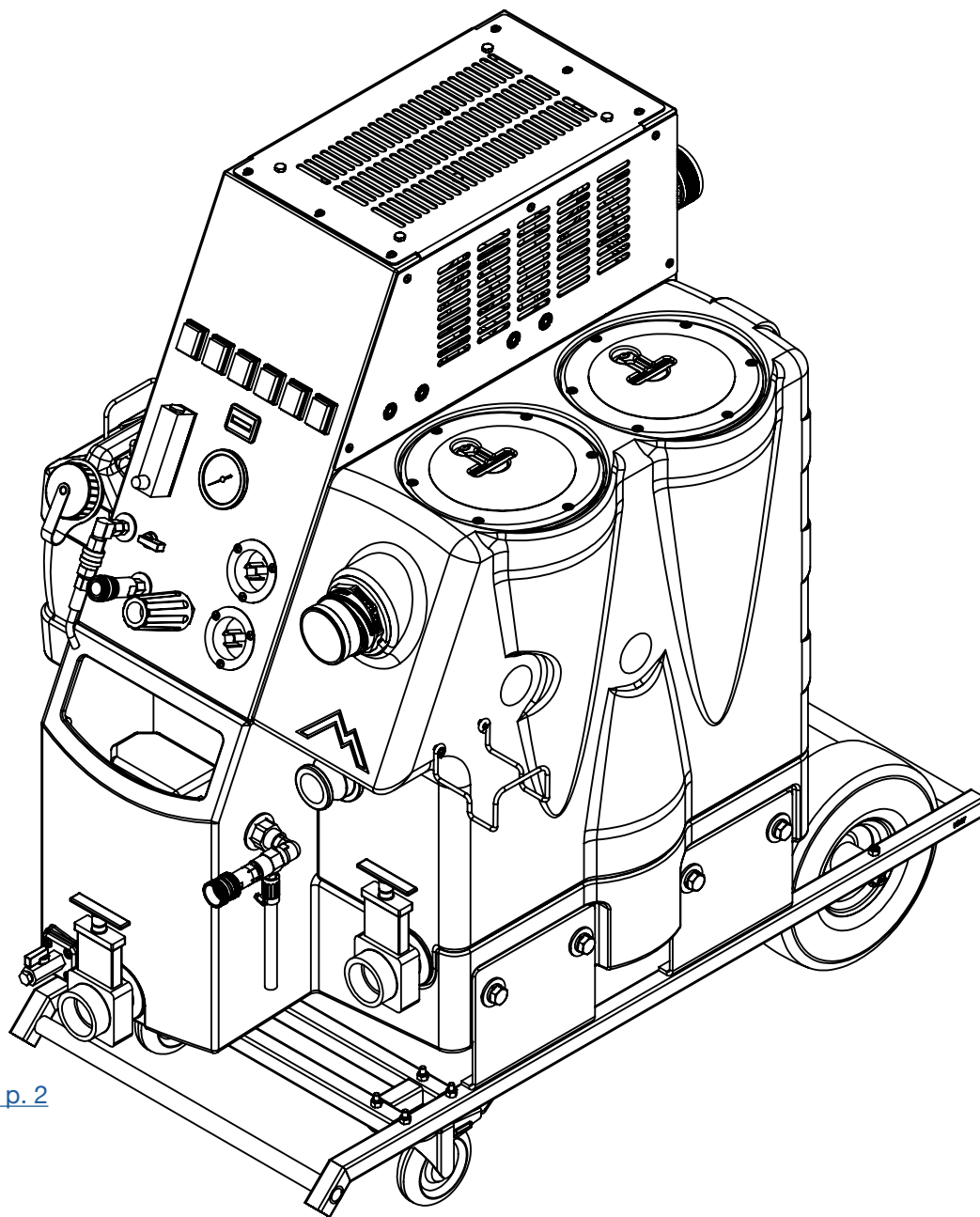

[General Information p. 2](#)

[Features p. 7](#)

[Switchplate p. 8](#)

[Power Options p. 9](#)

[Operation p. 10](#)

[Accessories p. 14](#)

[Parts & Pricing p. 16](#)

[Wiring Diagram p. 19](#)

[Vacuum System p. 21](#)

[Pump System p. 22](#)

[Auto-Fill & Chemical Injection System p. 23](#)

[Auto Pump-Out System p. 24](#)

Model # _____

Serial # _____

Form # ADP-ETM

6-16

GENERAL INFORMATION

Dear Customer:

Congratulations on the purchase of your new Escape™ ETM. As technology continues to develop you can work confidently knowing that both Mytee Products Inc. and its employees are equally dedicated to developing with the industry and its advances.

Like any other piece of machinery or technology, the ETM also requires the proper maintenance and care to keep the product working over extended use. Neglecting your machine, abusing it or not operating it properly can void its warranty and prevent the machine from performing to the quality and standard you'd expect out of the Mytee Products Inc. line.

If you have any warranty concerns or questions, please review this manual thoroughly or do not hesitate to contact your distributor. If there are questions regarding maintenance, replacement or ordering parts please contact an authorized Mytee Products Inc. Service Center. To see an updated list please visit our website at <http://www.mytee.com/support/service-centers/>

Before using your Mytee Product, please read this manually thoroughly. Sincerely,
Mytee Customer Care Dept.

Grounding Instructions

This machine must be grounded. If it should malfunction or breakdown, grounding provides a path of least resistance for electrical shock. This machine is equipped with a cord having an equipment-grounding conductor and grounding plug. The plug must be plugged into an appropriate outlet that is properly installed in accordance with all local code and ordinances. Do not remove ground pin; if missing, replace plug before use.



DANGER

Improper installation of the equipment-grounding conductor can result in a risk of electric shock. Be sure to check with a qualified electrician or service person if you are in doubt as to whether the outlet is properly grounded. If the plug will not fit in the outlet do not modify either the plug nor the machine's cord, instead have a proper outlet installed by a qualified technician.

This machine is for use on a nominal 120-volt circuit and with a grounding plug similar to the one in Figure 1 below. If a proper outlet is not available, follow the illustrations of Figure 2 & 3 to install a temporary-grounding plug. This temporary work-around should be used only until a proper outlet (Figure 1) can be installed by a qualified electrician. When and if this type of adapter is employed, screw the adapter's extended tab into place with a metal screw. However, grounding adapters are not approved for use in Canada.

Again, be sure to check the grounding pin for damages and replace if necessary.

The Green, or Green-Yellow, wire in the cord is the grounding wire. When replacing a plug, this wire must be attached to only the grounding pin.

DO NOT use extension cords.

Please Note for America use only

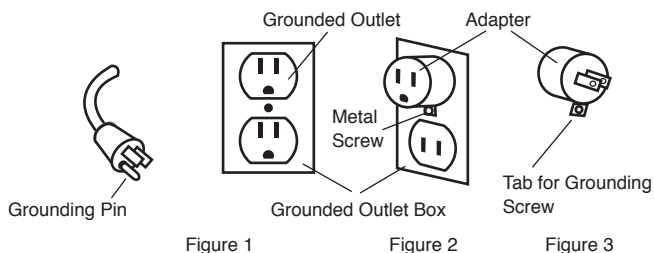

Parts and Service

Please contact a Mytee service personnel or Mytee authorized Service Center using Mytee original replacement parts and accessories for repairs are needing to be performed. When and if calling Mytee for support, please have your Model and Serial Number available for faster assistance.

Name Plate

The Model and Serial Number are located on the lower half of the back of the machine near the power plugs and will be required for ordering replacement parts. You can use the space provided on the front of this manual to note down both for future referencing.

Unpacking the Machine

When your new machine is delivered, please carefully inspect both the shipping carton and the machine for damages. If damage is evident, save both the shipping carton and machine so that the delivering carrier can inspect it. Contact the carrier immediately to file a freight claim if there has been any damage.

Caution and Warnings

Symbols

Mytee uses the symbols below to signal potentially dangerous conditions. Always read this information carefully and take the necessary steps to protect personnel and property.



DANGER

Is used to warn of immediate hazards that will cause severe personal injury or death.



WARNING

Is used to call attention to a situation that could cause severe personal injury.



CAUTION

Is used to call attention to a situation that could cause minor personal injury or damage to the machine or other property. When using an electrical appliance, basic precautions should always be followed, including the following: Read all instructions before using this machine. This product is intended for commercial use only.



WARNING

To reduce the risk of fire, electrical shock, or injury:

1. Read all instructions before using equipment.
2. Use only as described in this manual. Use only manufacturer's recommended attachments.
3. Always unplug power cord from electrical outlet before attempting any adjustments or repairs.
4. Do not unplug by pulling on cord. To unplug, grasp the plug, not the cord.
5. Do not pull or carry by cord. Do not close a door on cord or pull cord around sharp edges or corners.
6. Do not run appliance over cord. Keep cord away from heated surfaces.
7. Do not use with damaged cord or plug. If cord is damaged, repair immediately.
8. Do not use outdoors or on wet surfaces and or standing water.
9. Always unplug or disconnect the appliance from power supply when not in use.
10. Do not allow to be used as a toy. Close attention is necessary when used by or near children.
11. Do not use in areas where flammable or combustible material may be present.
12. Do not leave the unit exposed to harsh weather elements. Temperatures below freezing may damage components and void warranty.
13. Use only the appropriate handles to move and lift unit. Do not use any other parts of this machine for this purpose.
14. Keep hair, loose clothing, fingers, and all parts of the body away from

GENERAL INFORMATION

all openings and moving parts.

15. Use extra care when using on stairs.
16. To reduce the risk of fire or electric shock, do not use this machine with a solid-state speed control device.
17. The voltage and frequency indicated on the name plate must correspond to the wall receptacle supply voltage.
18. When cleaning and servicing the machine, local or national regulations may apply to the safe disposal of liquids which may contain: chemicals, grease, oil, acid, alkalines, or other dangerous liquids.
19. Do not leave operating unattended.

Escape Electronic Truckmount Unpacking the Machine

When your new machine is delivered, please carefully inspect both the shipping carton and the machine for damages. If damage is evident, save both the shipping carton and machine so that the delivering carrier can inspect it. Contact the carrier immediately to file a freight claim if there has been any damage.

Installation:

Due to the variety of mounting conditions, Mytee Products Inc. does not supply the necessary hardware to mount the ETM to the operating vehicle.

1. Do not attempt to move the ETM neither to nor from a vehicle with the tanks full.
2. Please refer to a qualified technician for safe and proper installation into your operating vehicle

Grounding Instructions

This machine MUST be grounded. If the machine should malfunction or break down, grounding provides a path of least resistance for the electrical current to safely dissipate. This machine is also manufactured with an equipment-grounding conductor and grounding-plug. The plug must be used on an appropriate outlet that is properly installed in accordance with all local code and ordinances. Do not remove the ground pin. If it is missing, replace the plug prior to use. Improper installation of the equipment-grounding conductor can result in a risk of electric shock. Be sure to check with a qualified electrician or service person if you are in doubt as to whether the outlet is properly grounded. If the plug will not fit in the outlet do not modify either the plug or the machine's cord, instead have a proper outlet installed by a qualified technician. This machine is for use on a nominal 120-volt circuit and with a grounding plug. If a proper outlet is not available, install a temporary-grounding plug. This temporary workaround should be used only until a qualified electrician can install a proper outlet. When and if this type of adapter is employed, screw the adapter's extended tab into place with a metal screw. However, grounding adapters are not approved for use in Canada. Again, be sure to check the grounding pin for damages and replace if necessary. The Green, or Green-Yellow, wire in the cord is the grounding wire. When replacing a plug, this wire must be attached to only the grounding pin. DO NOT use extension cords other than provided.

Machine Specifications

Solution Tank	12 gallons
Recovery Tank	12 gallons
Vacuum	Quad 3-stage
CFM	325
Water Lift	230" or 16.5" Hg
Pump PSI	900
Pump GPM	2.2
Pump-Out GPM	35
Power Consumption	Cord one: 20 amps @ 230V 60Hz/50Hz Cord two: 10 amps @ 230V 60Hz/50Hz
Machine Weight	200 lbs.
Machine Dimensions	Without cart: 32" x 21.25" x 36" With cart: 43" x 21.25" x 44.25"
Power Cord	Dual twist-lock 50' 12/3

Features:

1. Adjustable auto defoamer for Recovery Tank.
2. Adjustable auto feed chemical bottle for the solution tank with an adjustable Water-to-Chemical dial to control the solution's ratio.
3. Prime Valve for rinsing the Recovery Tank.
4. Adjustable 500-PSI regulator with a monitoring pressure gauge and motor-life hours counter.
5. Two vacuum pumps with a high-performance, 3-stage swiveling, noise reducing exhaust ports.
6. 2 ½" vacuum port with 2" Cuff-Lynx reducer.
7. 900 PSI Solution Pump
8. 35 GPM Pump-Out
9. Recovery & Solution Tank Drain Valves
10. Dual T-Handle Recovery Tank lids.
11. Internal, electronic vacuum motor Shut-Off switch.
12. Dual extension cord hangers.

Operating Instructions:

POWER CORDS

There are four basic ways to power your ETM:

1. Plug converter box into 3 prong dryer outlet (230V), then plug both power leads from the machine into the converter box.
2. Plug converter box into 4 prong dryer/range outlet (230V), then plug both power leads from the machine into the converter box.
3. Plug one of the ETM cords into the 115V hunter box (sold separately), which then plugs into two 115V outlets. This will allow you to use your pump and two of your vacuums for cleaning.
4. Locate 4 115V outlets, and plug in both hunter boxes (sold separately). This will allow you to run the entire unit. See the back of the converter boxes for more details.

TO OPERATE

1. Attach the end of a garden hose to the auto-fill male QD and other end to a water faucet.
2. Turn on the water until the automatic Shut-Off disengages water flow.
3. Using the hose attached to the primer, rest it inside the 2 ½" Vacuum Port and turn both vacuums on.
4. Locate the Pump Prime and run valve and set to the prime position and turn pump on.
5. Once water flows through prime hose switch the Prime Valve to run.
6. Regulate the PSI at ≤ 1000.
7. Attach the vacuum hose to the 2 ½" Cuff-Lynx hose port.
8. Connect a wand or other device to the front panel QD.
9. You may now begin cleaning.
10. When the vacuum shuts off you may need to drain the Recovery Tank using one of the three methods:
 - a. Release the drain valve.
 - b. Activate the 35 GPM pump out.
11. When finished, be sure to drain any remaining fluids from the hoses and wands.
12. Shut off all the switches.

After Use

1. Before storing the machine, drain, rinse and dry both the tanks and vacuum hoses of any residual water or solution.
 2. Store standing upright in a dry, enclosed location.
 3. Leave the recovery tank lid open for better air circulation.
- If storing in freezing temperatures, take extra precautions to make sure the machine and solution systems are completely drained and dry.

Filter Maintenance

All ETM models have three filters that need to be checked and cleaned after each week of use. Regular cleaning and changing of filters is a simple way to extend the life of your machines.

GENERAL INFORMATION

Vacuum Stack Filters

Located inside of the black vacuum tank are two pvc vacuum stacks. Each stack has one foam filter to help prevent waste material from getting into the vacuums and causing damage. To maintain these filters:

1. Remove 7" clear vacuum tank.
2. Reach in and pull out the two black filters located in the top ports of the vacuum stacks.
3. Clean filters of any debris and check for damage. If filters are not damaged, place them back into the stacks. If filters are damaged and falling apart, replace them.

Pump Filter

The pump filter is a half-circle shaped screed located on the inside bottom of the blue solution tank. To maintain filter:

1. Open black solution tank lid.
2. Reach into solution tank and rotate the dome shaped filter from its brass nipple by rotating it counter clockwise.
3. Check filter for any debris or damage to screen. Rinse filter of any debris or replace if damaged.
4. Place new or cleaned filter back onto brass nipple by rotating it clockwise.

ETM Float Switch Maintenance

Each ETM machine contains three water level float switches. These float switches control certain functions of the machine. The first float switch will control the auto-fill feature. The second float switch controls power to the vacuums. The third float switch controls when the large sump pump comes on and helps to prevent cavitation in the pump. Having these prevents water from getting into the vacuum stacks and from spilling out of the solution tank.

Vacuum Float Switch Maintenance and Replacement

Cleaning and maintaining float switches will help to extend the life your machine. Regular cleaning is required for proper functionality. To clean the vacuum level switch:

1. Remove 7" clear vacuum tank lid located on top of the vacuum tank.
2. Use a flashlight to locate the position of the float switch. The vacuum tank float switch will be located on the inside wall of the tank just below the vacuum ports.
3. Once located, reach in and hold the float switch finger all the way to one side by pushing on the opposite side.
4. Using your other hand, or finger, roll the clip off of its tabs by pulling on the bottom of the opposite tab from which you are pushing. It should not take a lot of pressure to remove the switch, so be careful not to break it.
5. Check float finger and where it attaches for debris or any other damage. If dirty, clean. If damaged, or one of the male tabs where the float hooks is damaged, refer to the float switch replacement section.
6. Once cleaned, replace float finger, flat side down, onto the male position tabs located on the float switch body in the vacuum tank. First, hook one side of the finger to one tab. Then roll and pull the tab with index finger until other clip snaps into place.
7. Check to insure float still works by turning on both vacuums with the vacuum tank lid off. Reach inside and lift the float finger. If vacuums turn off, the float works. If the vacuums stay on, float body may need replacement, or float finger is installed upside down.

Vacuum Float Switch Replacement

Required:

- Colored tape
- New float switch, rubber washer, and plastic nut
- Silicone
- Medium/deep depth 13/16" socket and ratchet
- Medium crescent wrench
- Phillips screwdriver or drill

1. Remove chemical injector kit attached to left side (sheet metal panel side opposite of vac tank) by taking off lid and removing bottle. Using Phillips head screw driver, remove ETM side panel by taking out the ten Phillips head screws holding panel onto machine. Be sure to slide the chemical injector hose through its panel opening to insure proper removal without causing any damage to chemical hose.

2. Locate vacuum float switch wires coming out of the black vacuum tank directly under the vacuums. Disconnect the two float switch wires that are plugged into the system.

3. At this point, use the colored tape to mark the wires that the float switch was unplugged from. The back end of the vacuum float switch should be visible. Remove the 7" clear vacuum tank lid located on top of the vacuum tank.

4. Use a flashlight to locate the position of the float switch inside of the tank. The vacuum float switch will be located on the inside wall of the tank below the vacuums.

5. Once located, reach in and hold the float switch finger all the way to one side by pushing on the opposite side.

1. Using your other hand, or finger, roll the clip off of its tabs by pulling on the bottom of the opposite tab from which you are pushing. It should not take a lot of pressure to remove the switch, so be careful not to break it.
2. Place the medium crescent wrench on the back nut of the float switch and the 13/16" socket on the inside nut of the float switch. Loosen the float by rotating the ratchet counter clockwise until completely loose.

Make sure not to lose any nuts or rubber washers in case they are needed in the future.

3. On the new float switch, hold the float switch finger all the way to one side by pushing on the opposite side.

4. Using your other hand, or finger, roll the clip off of its tabs by pulling on the bottom of the opposite tab from which you are pushing. It should not take a lot of pressure to remove the switch, so be careful not to break it

5. Place the rubber washer over the threads of the new switch and all the way down to the 13/16" nut side.

6. Place a thin layer of silicone on the rubber washer.

7. Thread float switch (with actuating finger off) wires back through vacuum tank hole and thread in using the 13/16" socket.

8. Using your hand, thread the plastic nut onto the back side of the float switch. Place medium crescent wrench on the nut to hold in place

9. Tighten the 13/16" float until snug. Make sure flat side of float body is facing towards the top of the vacuum tank.

10. Replace float finger, flat side down, onto the male position tabs located on the float switch body in the vacuum tank. First, hook one side of the finger to one tab. Then roll and pull the tab with index finger until other clip snaps into place.

11. Thread chemical injector hose back through side panel and replace all screws.

12. Reattach chemical injector bottle.

13. Check to insure new float switch works by turning on both vacuums with the vacuum tank lid off. Reach inside and lift the float finger. If vacuums turn off, the float works. If the vacuums stay on or will not turn on, the float finger may be installed upside down or wires were not connected completely.

Auto-fill Float Switch Maintenance and Replacement

Cleaning and maintaining float switches will help to extend the life your machine. Regular cleaning is required for proper functionality. To clean the auto-fill level switch:

1. Remove silver cover on the front of the blue solution tank by removing the four Phillips head screws.

2. Use a flashlight to locate the position of the float switch. The auto-fill float switch will be located on the inside wall of the tank just below the water inlet.

3. Once located, reach in and hold the float switch finger all the way to one side by pushing on the opposite side.

4. Using your other hand, or finger, roll the clip off of its tabs by pulling on the bottom of the opposite tab from which you are pushing. It should not take a lot of pressure to remove the switch, so be careful not to break it.

5. Check float finger and where it attaches for debris or any other damage. If dirty, clean. If damaged, or one of the male tabs where the float hooks is damaged, refer to the float switch replacement section.

6. Once cleaned, replace float finger, flat side down, onto the male position tabs located on the float switch body in the vacuum tank. First, hook one side of the finger to one tab. Then roll and pull the tab with index finger until other clip snaps into place.

GENERAL INFORMATION

7. Check to insure float still works by turning on both vacuums with the vacuum tank lid off. Reach inside and lift the float finger. If vacuums turn off, the float works. If the vacuums stay on, float body may need replacement, or float finger is installed upside down.

Auto-fill Float Switch Replacement

Required:

-Colored tape

-New float switch, rubber washer, and plastic nut

-Silicone

-Medium/deep depth 13/16" socket and ratchet

-Medium crescent wrench

-Philips screwdriver or drill

1. Remove silver cover on the front of the blue solution tank by removing the four Philips head screws
2. Remove chemical injector kit attached to left side (sheet metal panel side opposite of vac tank) by taking off lid and removing bottle.
3. Using Philips head screw driver, remove ETM side panel by taking out the ten Philips head screws holding panel onto machine. Be sure to slide the chemical injector hose through its panel opening to insure proper removal without causing any damage to chemical hose.
4. Locate vacuum float switch wires coming out of the blue solution tank directly behind the main pump. Disconnect the two float switch wires that are plugged into the system. At this point, use the colored tape to mark the wires that the float switch was unplugged from.
5. The back end of the vacuum float switch should be visible.
6. Use a flashlight to locate the position of the float switch inside of the tank. The vacuum float switch will be located on the inside wall of the tank below the vacuums.
7. Once located, reach in and hold the float switch finger all the way to one side by pushing on the opposite side.
8. Using your other hand, or finger, roll the clip off of its tabs by pulling on the bottom of the opposite tab from which you are pushing. It should not take a lot of pressure to remove the switch, so be careful not to break it.
9. Place the medium crescent wrench on the back nut of the float switch and the 13/16" socket on the inside nut of the float switch. Loosen the float by rotating the ratchet counter clockwise until completely loose. Make sure not to lose any nuts or rubber washers in case they are needed in the future.
10. On the new float switch, hold the float switch finger all the way to one side by pushing on the opposite side.
11. Using your other hand, or finger, roll the clip off of its tabs by pulling on the bottom of the opposite tab from which you are pushing. It should not take a lot of pressure to remove the switch, so be careful not to break it
12. Place the rubber washer over the threads of the new switch and all the way down to the 13/16" nut side.
13. Place a thin layer of silicone on the rubber washer.
14. Thread float switch (with actuating finger off) wires back through vacuum tank hole and thread in using the 13/16" socket.
15. Using your hand, thread the plastic nut onto the back side of the float switch. Place medium crescent wrench on the nut to hold in place
16. Tighten the 13/16" float until snug. Make sure flat side of float body is facing towards the top of the vacuum tank.
17. Replace float finger, flat side down, onto the male position tabs located on the float switch body in the vacuum tank. First, hook one side of the finger to one tab. Then roll and pull the tab with index finger until other clip snaps into place.
18. Thread chemical injector hose back through side panel and replace all screws.
19. Reattach chemical injector bottle.
20. Check to insure new float switch works by turning on water for auto-fill with the solution tank lid off. Reach inside and lift the float finger. If water stops, the float works. If the water keeps running, the float finger may be installed upside down or wires were not connected completely.

Sump Pump Switch Maintenance and Replacement Cleaning and maintaining float switches will help to extend the life your machine. Regular cleaning is required for proper functionality. To clean the sump level switch:

1. Remove 7" clear vacuum tank lid located on top of the vacuum tank.
2. Use a flashlight to locate the position of the float switch. The sump pump float switch will be located on the inside wall of the tank almost at the bottom.
3. Once located, reach in and hold the float switch finger all the way to one side by pushing on the opposite side.
4. Using your other hand, or finger, roll the clip off of its tabs by pulling on the bottom of the opposite tab from which you are pushing. It should not take a lot of pressure to remove the switch, so be careful not to break it.
5. Check float finger and where it attaches for debris or any other damage. If dirty, clean. If damaged, or one of the male tabs where the float hooks is damaged, refer to the float switch replacement section.
6. Once cleaned, replace float finger, flat side up, onto the male position tabs located on the float switch body in the vacuum tank. First, hook one side of the finger to one tab. Then roll and pull the tab with index finger until other clip snaps into place.
7. Check to insure float still works by turning on both vacuums with the vacuum tank lid off. Reach inside and lift the float finger. If vacuums turn off, the float works. If the vacuums stay on, float body may need replacement, or float finger is installed upside down.

Sump Pump Switch Replacement

Required:

-Colored tape

-New float switch, rubber washer, and plastic nut

-Silicone

-Medium/deep depth 13/16" socket and ratchet

-Medium crescent wrench

-Philips screwdriver or drill

1. Remove chemical injector kit attached to left side (sheet metal panel side opposite of vac tank) by taking off lid and removing bottle.
2. Using Philips head screw driver, remove ETM side panel by taking out the ten Philips head screws holding panel onto machine. Be sure to slide the chemical injector hose through its panel opening to insure proper removal without causing any damage to chemical hose.
3. Locate sump pump float switch wires coming out of the black vacuum tank directly under the behind the main pump. Disconnect the two float switch wires that are plugged into the system. At this point, use the colored tape to mark the wires that the float switch was unplugged from.
4. The back end of the vacuum float switch should be visible. Remove the 7" clear vacuum tank lid located on top of the vacuum tank.
5. Use a flashlight to locate the position of the float switch inside of the tank. The sump pump switch will be located on the inside wall of the tank near the bottom front.
6. Once located, reach in and hold the float switch finger all the way to one side by pushing on the opposite side.
7. Using your other hand, or finger, roll the clip off of its tabs by pulling on the bottom of the opposite tab from which you are pushing. It should not take a lot of pressure to remove the switch, so be careful not to break it.
8. Place the medium crescent wrench on the back nut of the float switch and the 13/16" socket on the inside nut of the float switch. Loosen the float by rotating the ratchet counter clockwise until completely loose. Make sure not to lose any nuts or rubber washers in case they are needed in the future.
9. On the new float switch, hold the float switch finger all the way to one side by pushing on the opposite side.
10. Using your other hand, or finger, roll the clip off of its tabs by pulling on the bottom of the opposite tab from which you are pushing. It should not take a lot of pressure to remove the switch, so be careful not to break it
11. Place the rubber washer over the threads of the new switch and all the way down to the 13/16" nut side.
12. Place a thin layer of silicone on the rubber washer.
13. Thread float switch (with actuating finger off) wires back through vacuum tank hole and thread in using the 13/16" socket.
14. Using your hand, thread the plastic nut onto the back side of the float

GENERAL INFORMATION

- switch. Place medium crescent wrench on the nut to hold in place
- Tighten the 13/16" float until snug. Make sure flat side of float body is facing towards the BOTTOM of the vacuum tank. This is the ONLY switch that will be positioned this way.
 - Replace float finger, flat side up, onto the male position tabs located on the float switch body in the vacuum tank. First, hook one side of the finger to one tab. Then roll and pull the tab with index finger until other clip snaps into place.
 - Thread chemical injector hose back through side panel and replace all screws.
 - Reattach chemical injector bottle.
 - Check to insure new float switch works by turning on the sump pump on with the vac tank lid off. Reach inside and lift the float finger. If sump turns on. The float works. If the sump will not turn on, or will not turn off, the float finger may be installed upside down or wires were not connected completely.

Oil Maintenance:

Each machine using the General Pump Head will need its first oil change within 50-100 hours, then every three months or 500 hours after. Regular lubrication is the easiest, most efficient and least expensive element in preventative maintenance, according to General Pump.

Weekly

- Check oil for proper levels:
- If oil is milky or discolored, change immediately.
- Check pump for oil leaks:
- If the pump shows signs of oil leaks between the crankcase/manifold, the piston rod oil seals will need replacing.
- If oil leaks out of the side covers, the side cover's oil seals need to be changed immediately.
- Check pump for water leaks:
- If the water leaks between the crankcase/manifold, change the packing assembly immediately.
- If water leaks from the valve caps, change the valve cap O-Rings.
- Check regulator for proper operating and bypass pressure.
- Check all fittings for proper tightness to prevent leakage. Tighten loose nuts, bolts and fasteners.

Instructions for Oil Change

For all other repairs, locate a Mytee Service Center for repairs.

Required Equipment:

- 9/16" Wrench or socket.
- 13/16" Socket with ratchet to fit.
- Phillips head screw driver or drill.
- 12 oz SAE 30w Oil
- Oil catch pan capable of holding 12 oz of oil (Height ≤ 2")
- Oil funnel capable of fitting oil port on top of General Pump head brass tee (3/8" diameter)
- Pliers
- Flash light (Optional)

- Cover ground with cardboard or any available scrap material to prevent unwanted spills and stains.
- Remove chemical injector kit attached to left side (Sheet metal-panel side opposite of vacuum tank) by taking off the lid and removing the bottle.
- Using a Phillips head screwdriver, remove the ETM side panel by unscrewing ten Phillips head screws holding the panel onto the machine. Be sure to slide the chemical injector hose through its panel opening to ensure proper removal without causing any damage to the chemical hose.
- Slide ≤ 2" oil catch pan under the ball valve located under the bottom front of the machine and to the left of the solution tank drain.
- Release the two rear latches by turning its wings to the left then open top half of the machine completely to expose the main pump.
- Place open-end of the 13/16" wrench onto the silver ball valve to ensure zero rotation during plug removal. Using a 9/16" wrench to loosen the brass plug on the front of the ball valve to remove the plug.
- Unscrew then 7/8" oil plug from under the machine until finger loose.
- Completely remove the drain plug by hand and open the ball valve to allow the oil to drain into the catch pan.
- Once the oil has stopped or slowed to a few drips, close the ball valve with a 13/16" wrench, hold the ball valve in place and replace the 9/16" oil

- plug with new Teflon wrapped around the threads.
- Using a funnel, pour 12oz of SAE 30w oil into the top of the General Pump head through the brass tee.
 - Use a flashlight to check the side of the General Head to ensure the oil level reaches the midpoint of the view glass. Add or remove oil as needed.
 - Replace the plastic vent cap using pliers.
 - Thread the chemical injector hose back through the side panel and replace all its screws.
 - Reattach the chemical injector bottle.
 - Dispose of any old oil and continue normal use of the machine.

Maintenance item	Daily	Once a week
Clean and inspect tanks.	x	
Clean and inspect hoses.	x	
Check and clean internal filters by twisting off, rinsing with clean water and replacing.	x	
Check power supply cable.	x	
Clean machine with all-purpose cleaner and cloth.	x	
Check spray nozzles.	x	
Flush solution system with Mytee® System Maintainer.		x
Remove and float shut-off screen from tank and clean. Simply pull off.		x
Inspect vacuum hoses for holes and loose cuffs.		x
Inspect spray pattern for clogging. If clogged, remove spray tips and soak them in a recommended liquid neutralizer for up to six hours. To remove spray tip, twist spray tip body counter-clockwise.		x
Lubricate wheels with water resistant oil.		x
Inspect machine for water leaks and loose hardware.		x

Generators for use with Escape® Electric Truck Mount

Mytee Products recommends the use of a 10,000--watt generator with this unit. This will supply ample power for the ETM.

However, the Escape can be run on some 8,000--watt generators, depending on the manufacturer. Generators are rated differently, so if using 8,000--watt generator the rating must represent continuous running watts, not peak watts.

In any case, check with the Generator manufacturer to ensure the unit can provide 30 amps at 230 volts continuously.

ESCAPE™ ETM

ESCAPE™ ETM FRONT

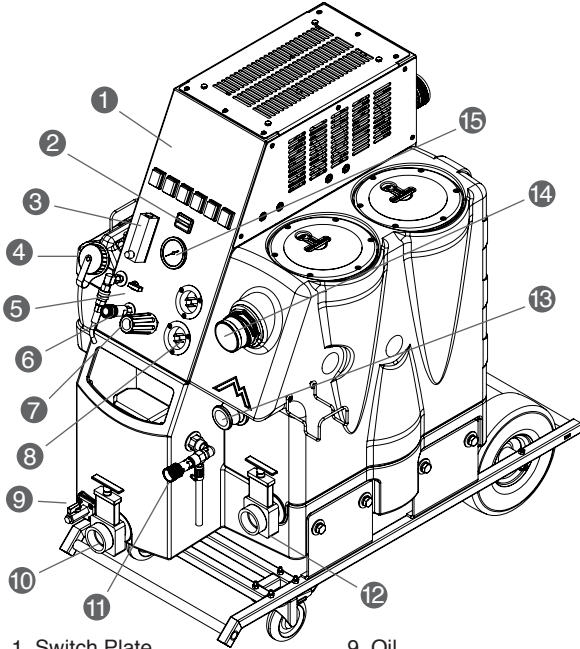

- | | |
|---------------------------------|-------------------------------|
| 1. Switch Plate | 9. Oil |
| 2. Hour Meter | 10. Solution Tank Drain Valve |
| 3. Chemical Reader | 11. Auto Fill |
| 4. Chemical Bottle | 12. Recovery Tank Drain Valve |
| 5. Prime Valve | 13. Pump-Out |
| 6. Female Quick Disconnect (QD) | 14. 2" Male Cuff-Lynx™ Inlet |
| 7. Pressure Regulator | 15. PSI Gauge |
| 8. Electrical Power Ports | |

ESCAPE™ ETM BACK

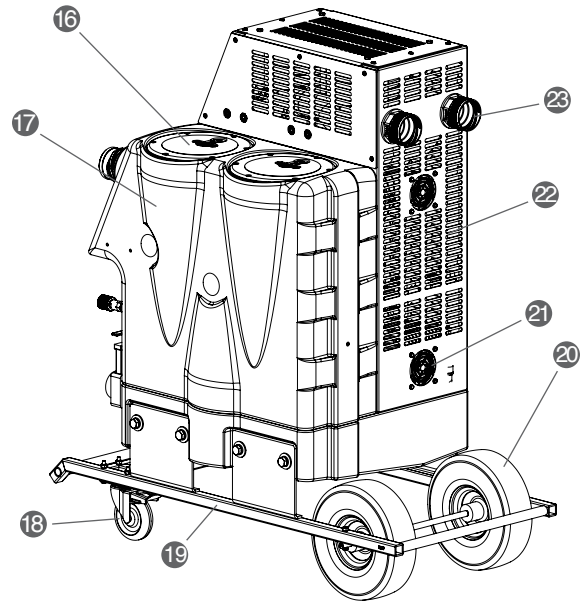

- | | |
|---|-------------------------|
| 16. Recovery Lids | 23. Rear Vacuum Exhaust |
| 17. Recovery Tank | |
| 18. 4" Locking Casters | |
| 19. Cart | |
| 20. 10" foam filled semi-pneumatic wheels | |
| 21. Rear Cooling Fans | |
| 22. Top, Rear & Side Vents | |

ESCAPE™ ETM ACCESSORY ITEMS INCLUDED

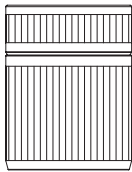

H107 Cuff-Lynx™
2.5" x 2.5" Hose Adapter

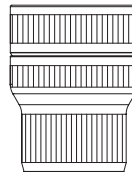

H106 Cuff-Lynx™
2.5" x 2" Hose Reducer

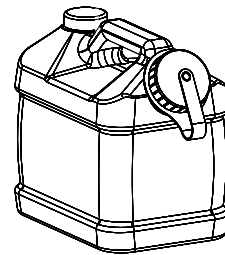

Chemical Bottle

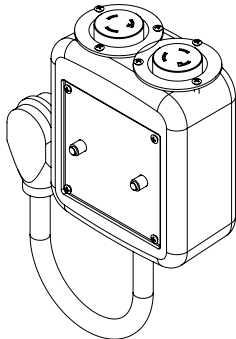

5005
3-prong Electrical Converter

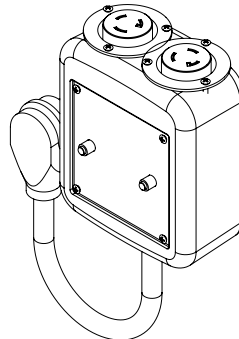

5006
4-prong Electrical Converter

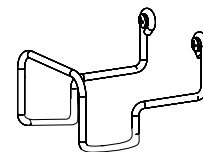

Hook (x2)

ESCAPE™ ETM SWITCH PLATE AND POWER SOCKETS

Top Socket: Powers Vac 1, Vac 2 Pump, & Pump-out.

Bottom Socket: Powers Vac 3 and Vac 4.

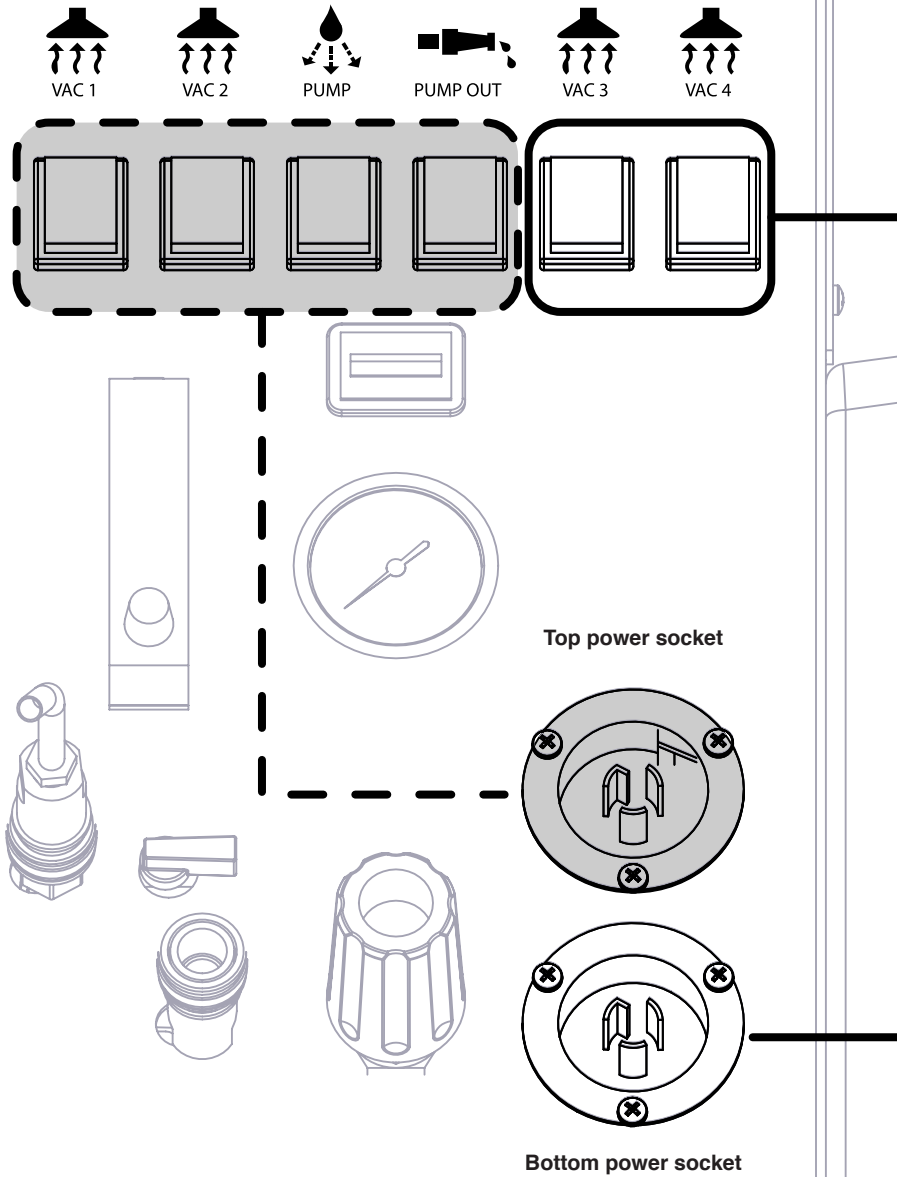

Plug in to top socket to use vacuum 1 or 2, pump or pump-out. To use vacuum 3 or 4 plug in bottom socket.

ESCAPE™ ETM POWER OPTIONS 1 & 2

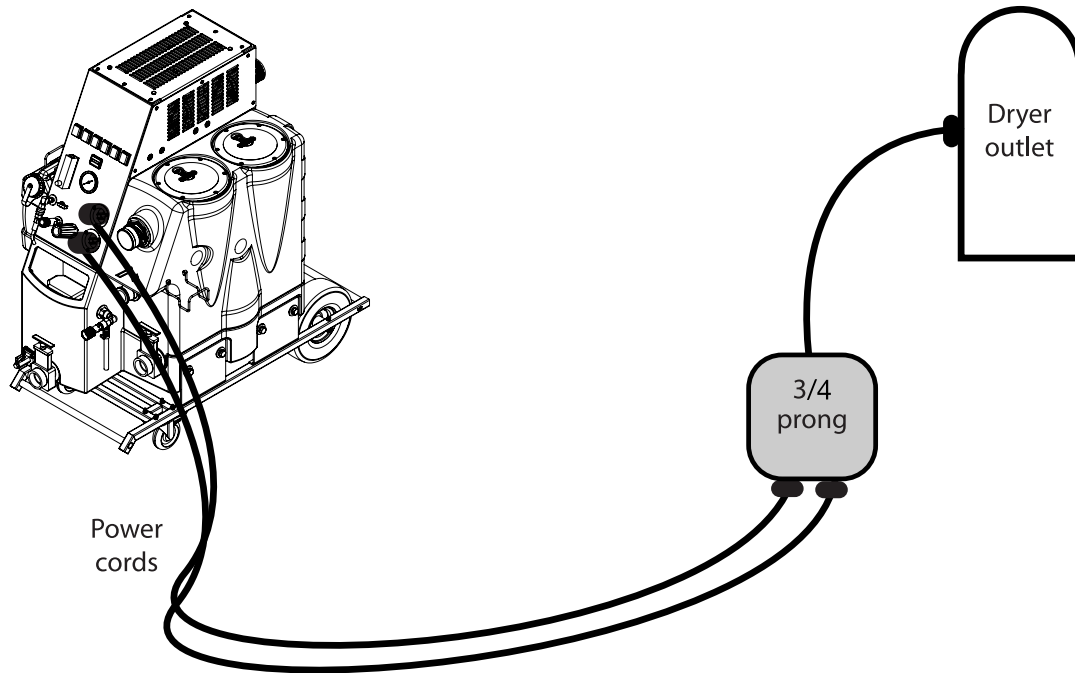

Plug each 50' power cord into the 3 or 4 prong electrical adaptor. Once connected, plug electrical adaptor into dryer outlet.

ESCAPE™ ETM POWER OPTION 3 USING HUNTER BOXES (SOLD SEPARATELY)

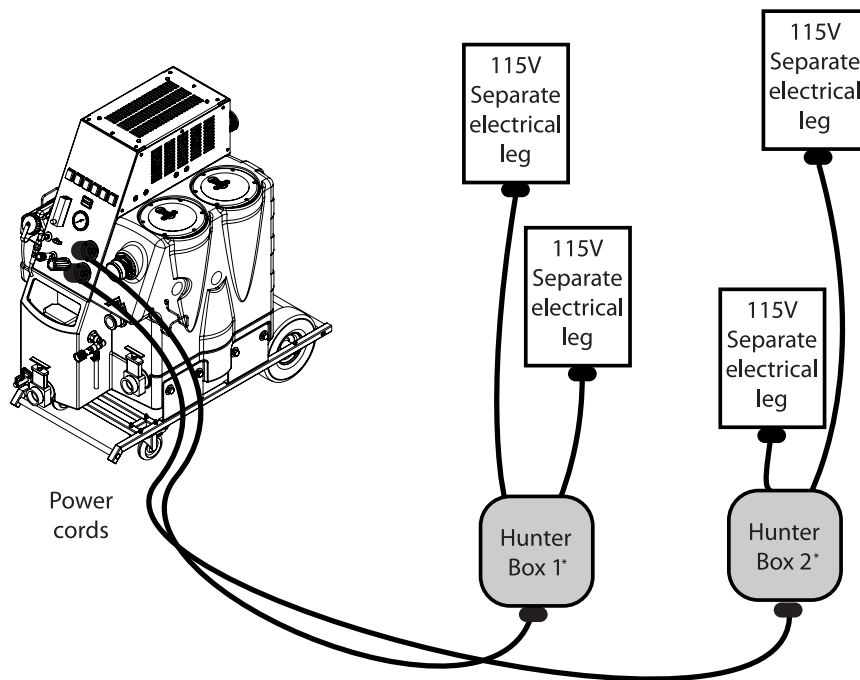

*sold separately

Plug each 50' power cord in the hunter boxes (sold separately - part # 5007). Once connected to the hunter boxes, plug each cord in to four separate 115 volt electrical legs.

ESCAPE™ ETM USAGE METER

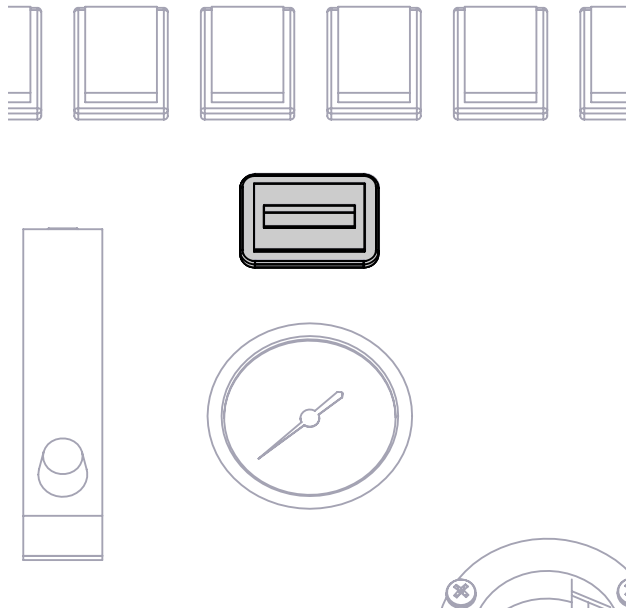

Keep track of how many hours your system has been operating with this usage meter. Great to help schedule an oil change and other scheduled maintenance.

ESCAPE™ ETM CHEMICAL METER

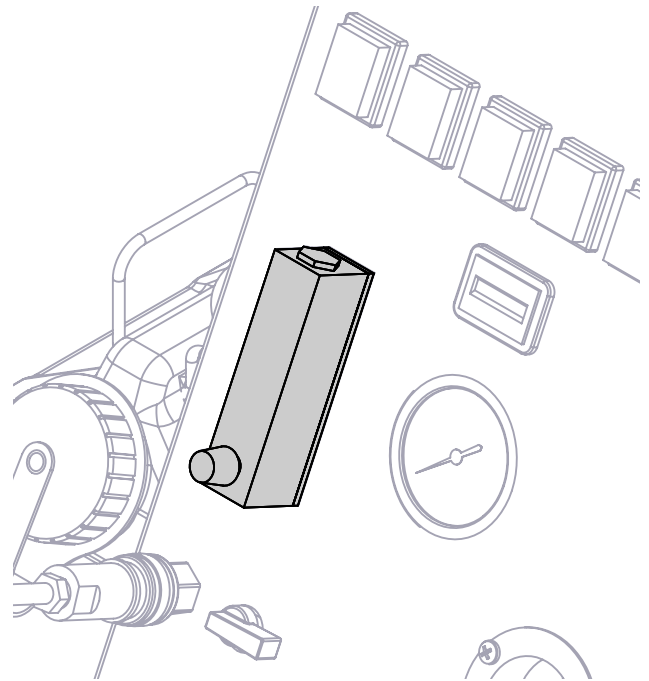

The adjustable chemical meter is located on the switch plate. Adjust accordingly.

ESCAPE™ ETM PSI GAUGE & REGULATOR

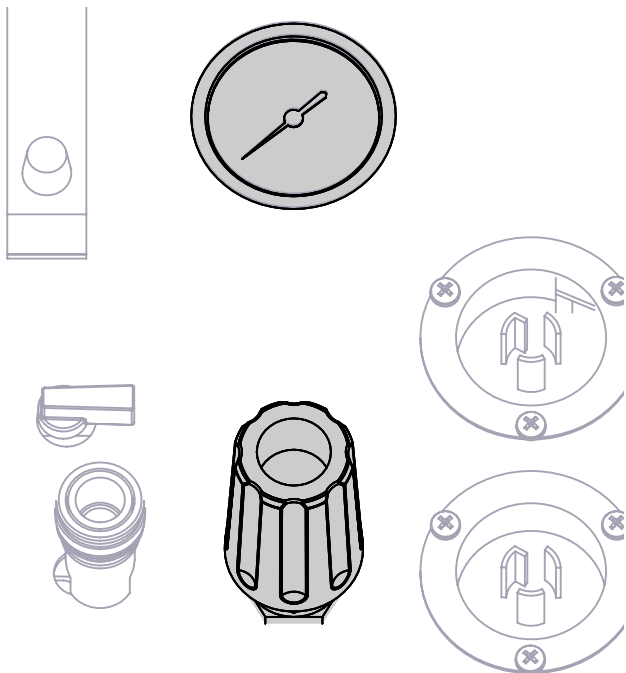

The gauge allows you to monitor PSI levels. Turning the Pressure Regulator to its left will decrease water pressure and turning to the right will increase water pressure. *Please refer to the Pressure Gauge to monitor your water pressure.

ESCAPE™ ETM PUMP PRIME / WASH OUT HOSE

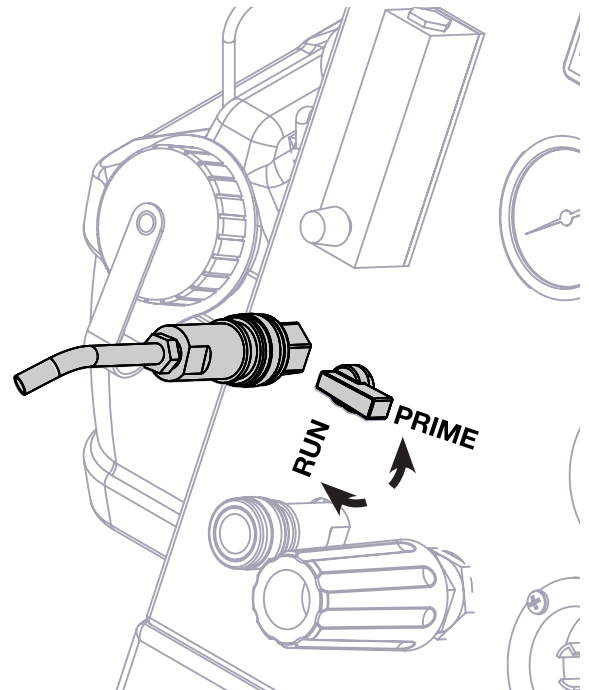

The wash out hose is available for rinsing out recovery tank.

ESCAPE™ ETM SOLUTION HOSE AND VACUUM HOOK UP

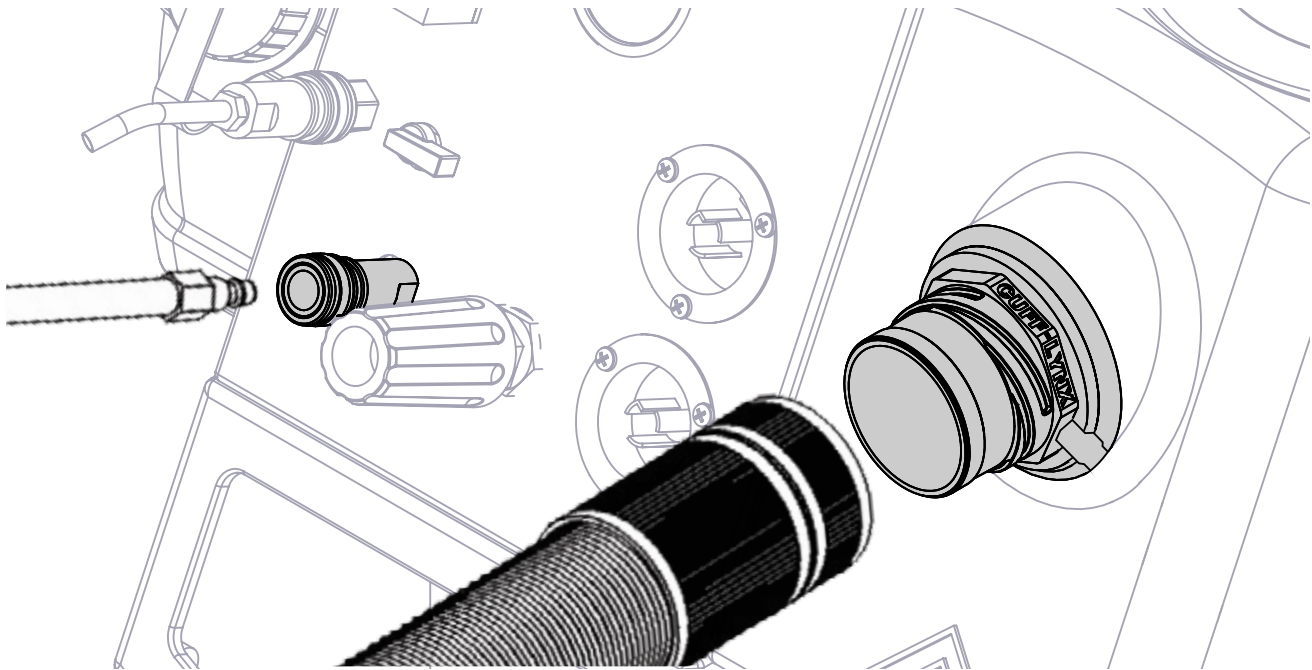

Attach female end of a solution hose to a wand or tool then attach male end of QD to ETM. Attach hose along with a 2.5" Cuff-Lynx™ hose adapter to the ETM's hose port. Then connect a vacuum hose or tool to other end of hose.

HOW TO USE ESCAPE™ ETM CHEMICAL BOTTLE AND METER

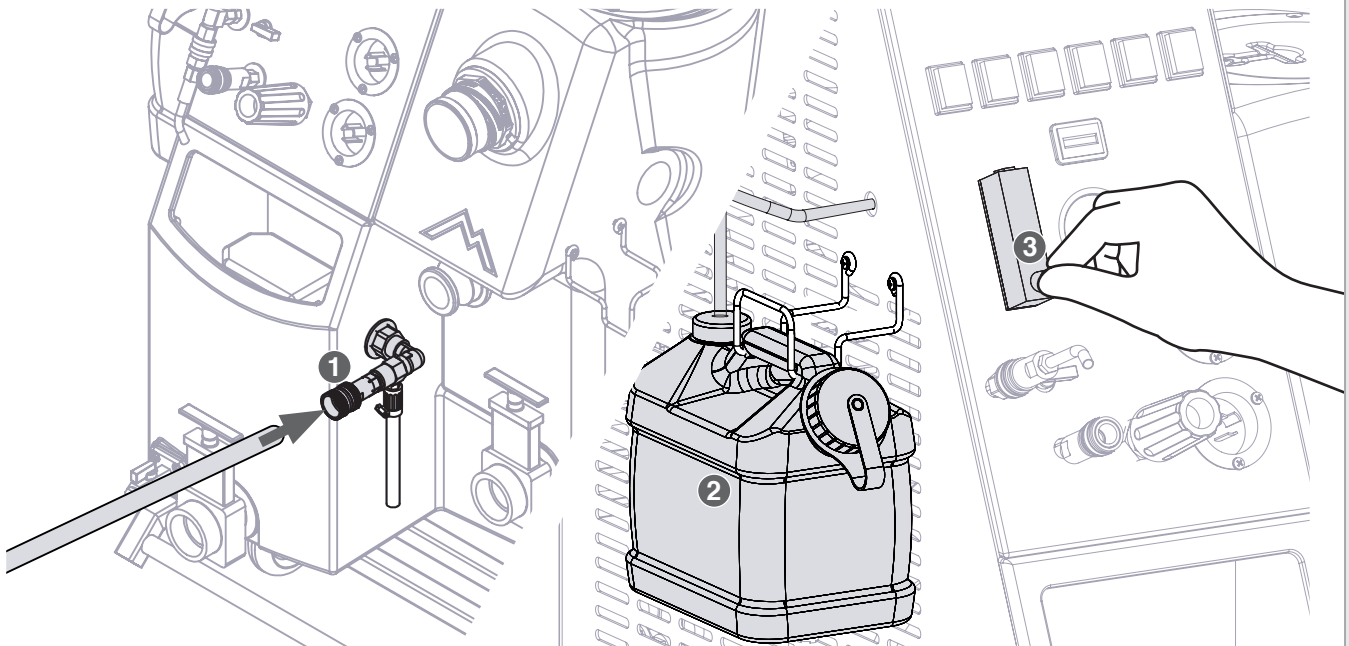

(1) Hook up standard garden hose to the auto-fill fitting. Incoming pressure should be 40 PSI or lower. (2) Hang the included chemical bottle (part # P535) from the side of the machine and fill it with the desired chemical concentrate. (3) Set meter to desired ratio. Meter is measured in GPH (Gallons Per Hour), which indicates how many gallons per hour of concentrated chemical will be metered.

Begin running the machine. As the solution tank fills with water through the auto-fill port, chemical will automatically be injected. Make sure the injector in the tank (where the clear hose hooks up) is fully open. Chemical will only be drawn while the tank is filling.

ESCAPE™ ETM AUTO FILL & SOLUTION TANK DUMP VALVE

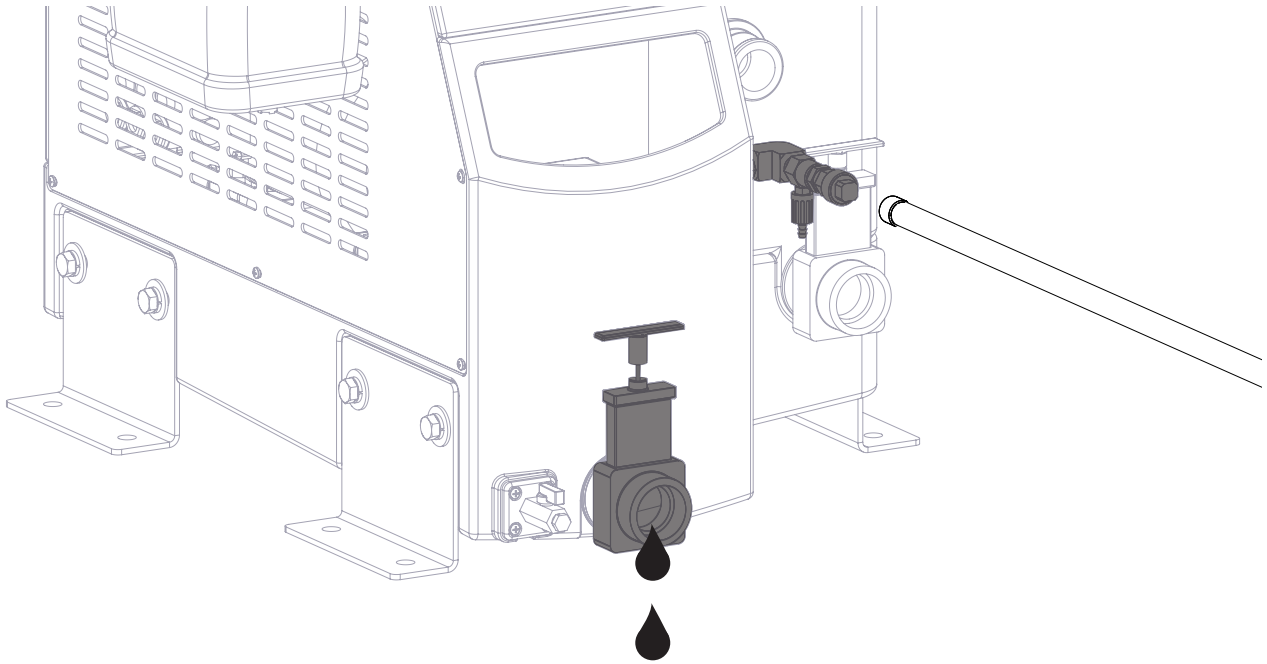

For a convenient way to fill up the ETM's solution tank, connect a water hose to the auto-fill. This will help speed up the work flow. Once the water level reaches a certain point the water stops, then refills again. Empty the solution tank by pulling the solution tank dump valve.

ESCAPE™ ETM PUMP OUT HOOK UP & RECOVERY TANK DUMP VALVE

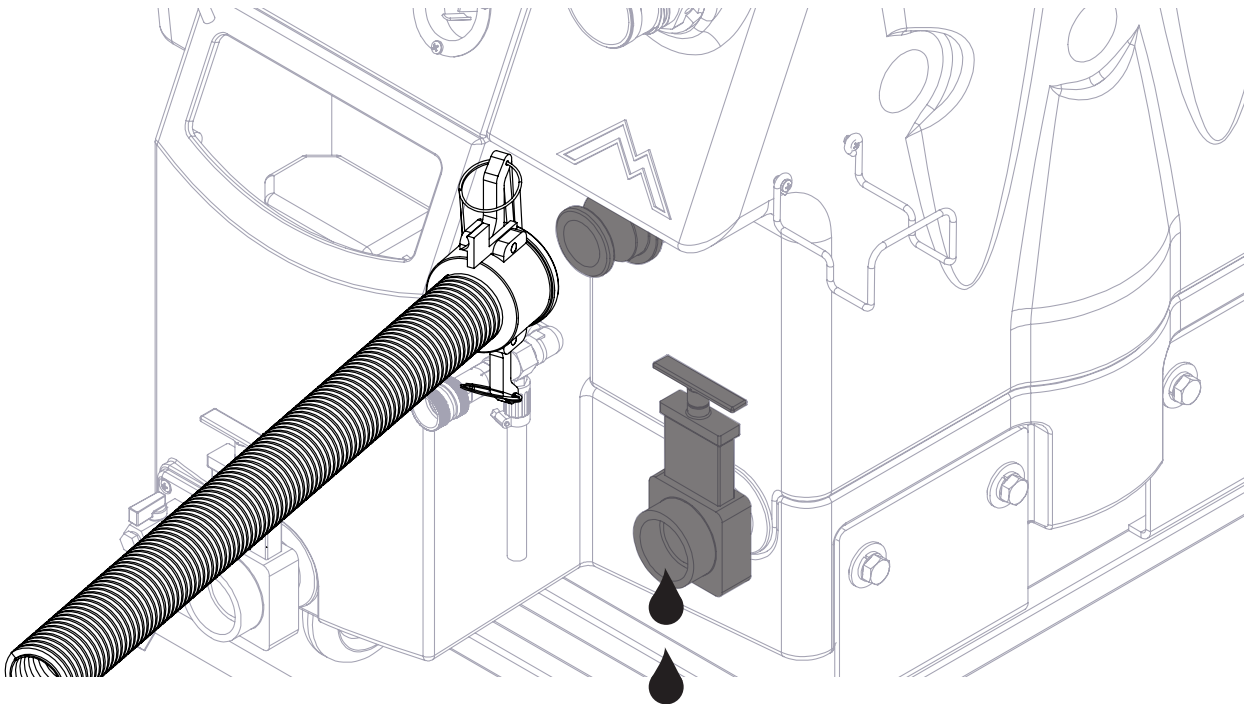

Attach hose bearing cam lock to the Pump-out fitting. Secure the hose to the fitting using the cam lock. Push the hose cuff onto the fitting, making sure the silver ears and rings are extended forward. Pull the ears down using the rings until connection is tight. Place the end of the hose in a location where dirty water can drain. Using the recovery tank drain valve is also available.

ESCAPE™ ETM CLEAR T - LIDS

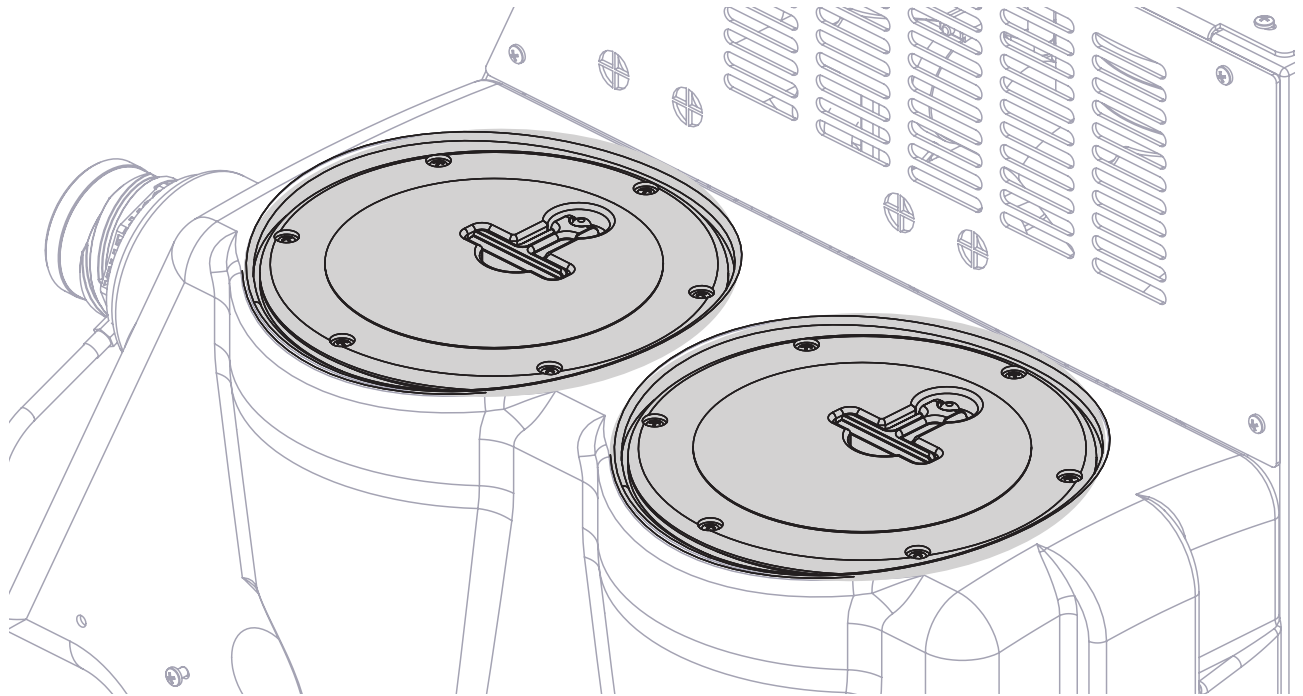

Recovery tank lids for easy entry.

ESCAPE™ ETM OIL CHANGE

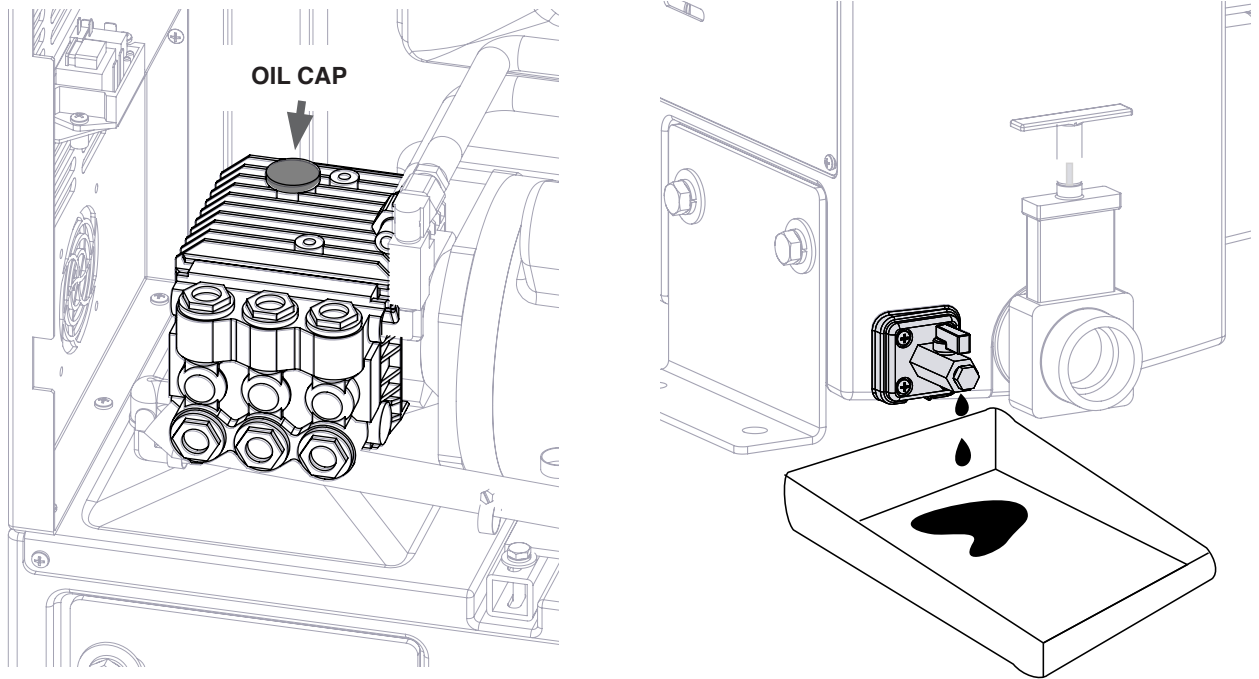

After you have removed the chemical bottle and side panel, unscrew yellow cap marked 'Oil'. Be mindful of the O-ring. At the front of the unit, place an oil catch underneath valve and remove valve brass cap - open valve. Oil we begin to flow through, once oil empties replace cap and close valve. Now oil can be added (11 ounces is recomended). Use funnel if needed.

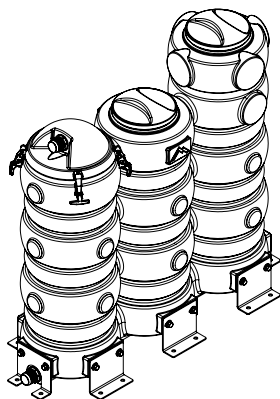

T-80R - Recovery Tank

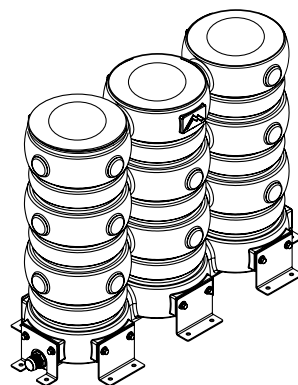

T-80S - Solution Tank

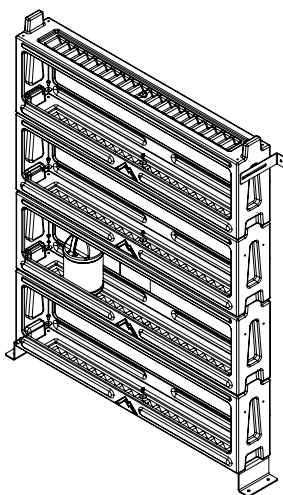

**A500 - Stackable Van
Shelving System Set**

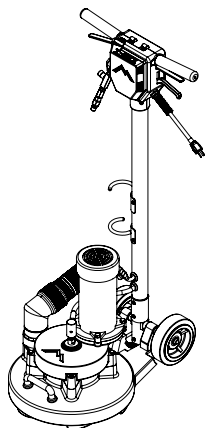

**T-REX™ - Total
Rotary Extraction**

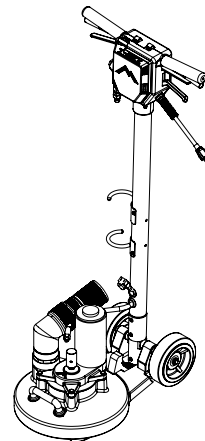

**T-REX™ Jr. - Total
Rotary Extraction**

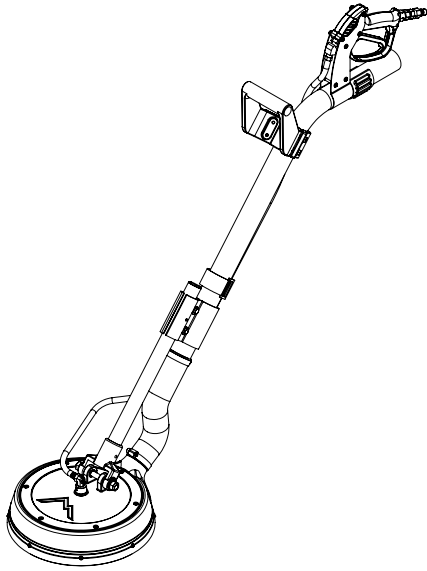

**8901 - Wand Style
2" Spinner®**

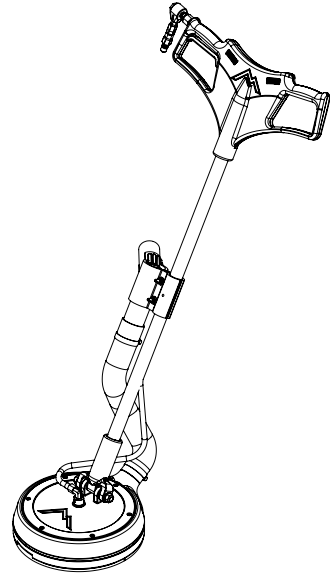

**8902 - "T" Style
2" Spinner®**

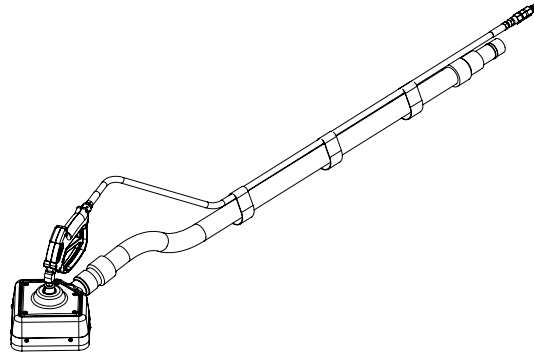

8908 - Counter Spinner®

ESCAPE™ ETM PARTS & PRICING

ITEMS NOT SHOWN			
PART NO.	DESCRIPTION	QTY.	MSRP
A959	harness, electrical	1	\$74.99 ea
E351	power cord, ext. 50', 12/3, twist lock	2	\$78.99 ea
H106	Cuff-Lynx, 2" hose x 2.5" female	1	\$4.99 ea
H107	Cuff-Lynx, 2.5" hose x 2.5" f swivel	1	\$4.99 ea
H294	vac hose, 1-1/2" x 2.5" SW	1	\$74.99 ea
H205	cam & groove fitting 1-1/2", female w/ lock	1	\$32.99 ea
5005	electrical adaptor ETM - 3 prong	1	\$169.99 ea
5006	electrical adaptor ETM - 4 prong	1	\$159.99 ea
ADM-ETM	ETM manual	1	

ITEM NO.	PART NO.	DESCRIPTION	QTY.	MSRP
1	F505	ETM Sol Tank / Chassis	1	\$224.99 ea
2	H541A	valve, float, autofill	1	\$108.99 ea
3	H097	washer, 1"ID x 1.5"OD, flat, s/s	2	\$0.99 ea
4	H182	adapter, 3/4" fgn x 1/2" fpt	1	\$12.99 ea
5	B273	elbow, 90 deg street, 3/8" fpt x 1/2" mpt	1	\$8.99 ea
6	H541C	chemical injector	1	\$39.99 ea
7	B204	qd, 3/4" female x female garden hose	1	\$9.99 ea
8	B205B	GD, 1/2" npt x 3/4" mgh, pump-out	1	\$3.99 ea
9	B272	adapter, 1/2" fpt x 3/8" mpt	1	\$16.99 ea
10	PH634-33	sol hose, 1/4", silicone braided, clear	6	\$6.49 ft
11	H170	female, 1/4", brass	6	\$0.99 ea
12	B109	adapter, brass, 1/4" barb x 1/4" mpt	4	\$1.99 ea
13	H484	plate, mounting, OD	1	\$4.99 ea
14	B656B	valve, ball, 1/4" fpt x 1/4" fpt, s/s	2	\$13.49 ea
15	B127	plug, brass, 1/4" mpt, hex	2	\$0.99 ea
16	H230	screw, 10-32 x 1/2" phil pan head, s/s	38	\$0.99 ea
17	H225	valve, drain, 1-1/2"	2	\$20.99 ea
18	H203	bol, 1/4-20 x 1-1/4" hex head, s/s	2	\$0.99 ea
19	H210	washer, 1/4" lock, s/s	10	\$0.99 ea
20	H196	washer, 1/4" flat, s/s	10	\$0.99 ea
21	H196	support pump, truckmount	1	\$18.99 ea
22	H201	bol, 1/4-20 x 1/2" hex head, zinc	2	\$0.99 ea
23	PH615-35	sol hose, 1/2", silicone braided clear	1	\$8.99 ft
24	B173	female, 1/2", brass	3	\$0.99 ea
25	B644	adapter, brass, 1/2" barb x 1/4" mpt	1	\$2.49 ea
26	B119	filter, strainer, 1/4"	1	\$3.99 ea
27	H012	instrument panel, truck mount	1	\$185.99 ea
28	E628A	controller, water level, single, 230V	1	\$114.99 ea
29	H273	nut, kep, #10-32 zinc	7	\$0.99 ea
30	E360	flanged male inlet receptacle, 230V, 20A	2	\$28.99 ea
31	PH634-20	sol hose, 1/4", silicone braided, clear	1	\$6.49 ft
32	H046	screw, 10-32 x 3/8", phil pan, zinc	2	\$0.99 ea
33	H289	washer, 10 flat, s/s	2	\$0.99 ea
34	AH184	hose, pulse, 3/8" x 14.5", 1/4 FSW x 1/4 FPT	2	\$27.99 ea
35	PH634-24	sol hose, 1/4", silicone braided, clear	1	\$6.49 ft
36	B652	elbow, brass, 90 deg, 3/8" mpt x 1/4" mpt	2	\$8.49 ea
37	H306C	unloader, 1200 psi	1	\$125.99 ea
38	B103	elbow, brass, 90 deg, 1/4" mpt x 1/4" fpt	8	\$4.49 ea
39	H876	washer, 1/2" flat, s/s	5	\$0.99 ea
40	B110	adapter, brass, extender, 1/4" mpt x 1/4" fpt, hex	2	\$3.49 ea
41	B102	ad, brass, 1/4" fpt x 1/4" fpt	1	\$17.99 ea
42	B142A	coupling, brass, 1/4" fpt x 1/4" fpt	4	\$4.49 ea
43	B135	tee, brass, 1/4" mpt	1	\$5.49 ea
44	PH634-36	sol hose, 1/4", silicone braided, clear	1	\$6.49 ft
45	B110	adapter, brass, 1/4" sw barb x 1/4" fpt, w/gasket	1	\$3.99 ea
46	B259	ad, brass, 1/4" fpt x mpt	1	\$11.99 ea
47	B260	ad, brass, 1/4" mad x fpt	1	\$10.49 ea
48	B107	nipple, brass, 1/4"m, hex	4	\$3.19 ea
49	B136	elbow, brass, 90 deg, 1/4" mpt x 1/4" mpt	3	\$4.99 ea
50	H325	flow meter, electric truckmount	1	\$189.99 ea
51	G069	gasket, flow meter	1	\$0.99 ea
52	B129	nipple, hex, 1/8" mpt x 1/8" mpt	2	\$1.99 ea
53	B131	fitting, 1/4" barb x 1/8" FPT	2	\$2.99 ea
54	H308D	gauge, pressure, 200psi	1	\$36.99 ea
55	B130	45 deg, street elbow, brass, 1/4" male	1	\$5.49 ea
56	E369	hour meter, panel mount, analog	1	\$35.99 ea
57	E515	switch, rocker, 2 position	6	\$13.99 ea
58	H009	side panel, truckmount	1	\$189.99 ea
59	F535	bottle, 5 quart, w/ caps	1	\$16.99 ea
60	G036	cap, 2.5" threaded, tethered	1	\$3.49 ea
61	H547	hanger, wire for injection sprayer	1	\$7.49 ea
62	H456B	cap (only) w/ hole	1	\$3.99 ea
63	PH634-35	sol hose, 1/4", silicone braided, clear	1	\$6.49 ft
64	B117	strainer, with check, chemical injector	1	\$16.99 ea
65	C332	pump head, general, 2.1 GPM	1	\$569.99 ea
66	B186	elbow, brass, 90 deg, 3/8" mpt x 3/8" fpt	1	\$8.99 ea
67	B172	elbow, brass, 90 deg, 1/2" barb x 3/8" mpt	1	\$9.49 ea
68	B105	bushing, brass, 3/8" mpt x 1/4"	1	\$3.19 ea

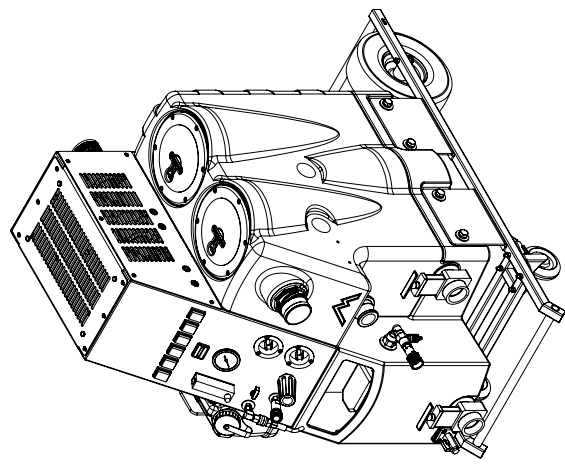

NAME	DATE	MY TEE PRODUCTS, INC.
DRAWN	12/2013	
CHECKED		
COMMENT:		
TITLE: ETM SIZE: DWG. NO. C ETM_230V SCALE: 1:8 SHEET 1 OF 5		

Part prices are subject to change.

ESCAPE™ ETM PARTS & PRICING

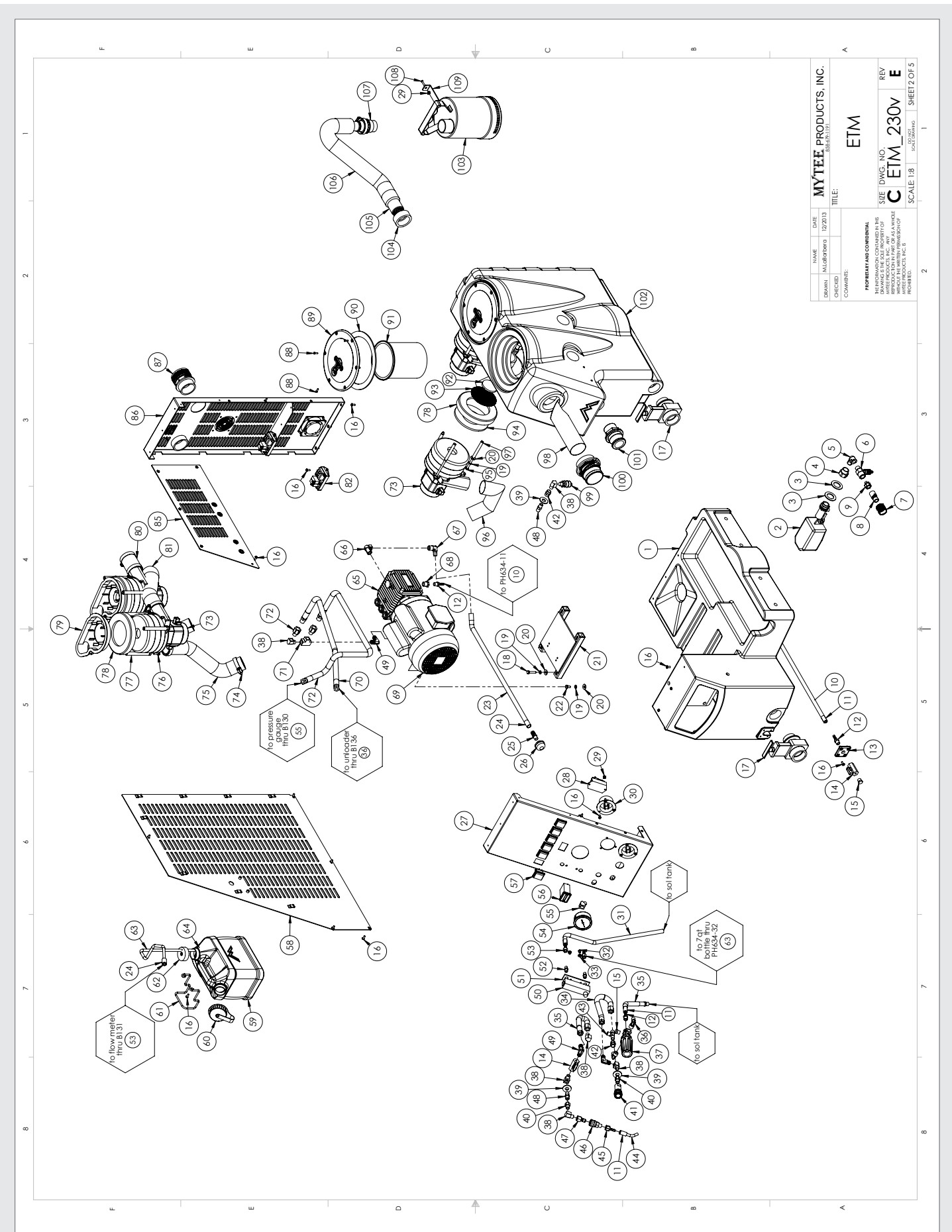

NAME	DATE	MY TEE PRODUCTS, INC.
DESIGNER	12/2013	1888/2017
CHECKED		
COMMENTS		
PROPRIETARY AND CONFIDENTIAL INFORMATION CONTAINED IN THIS DRAWING IS THE SOLE PROPERTY OF MY TEE PRODUCTS, INC. AND IS TO BE USED FOR THE PARTS AND SERVICES OF MY TEE PRODUCTS, INC. ONLY.		
SIZE	DWG. NO.	REV.
C	ETM_230V	E
SCALE: 1:8	SHEET NO.	SHEET 2 OF 5

ESCAPE™ ETM PARTS & PRICING

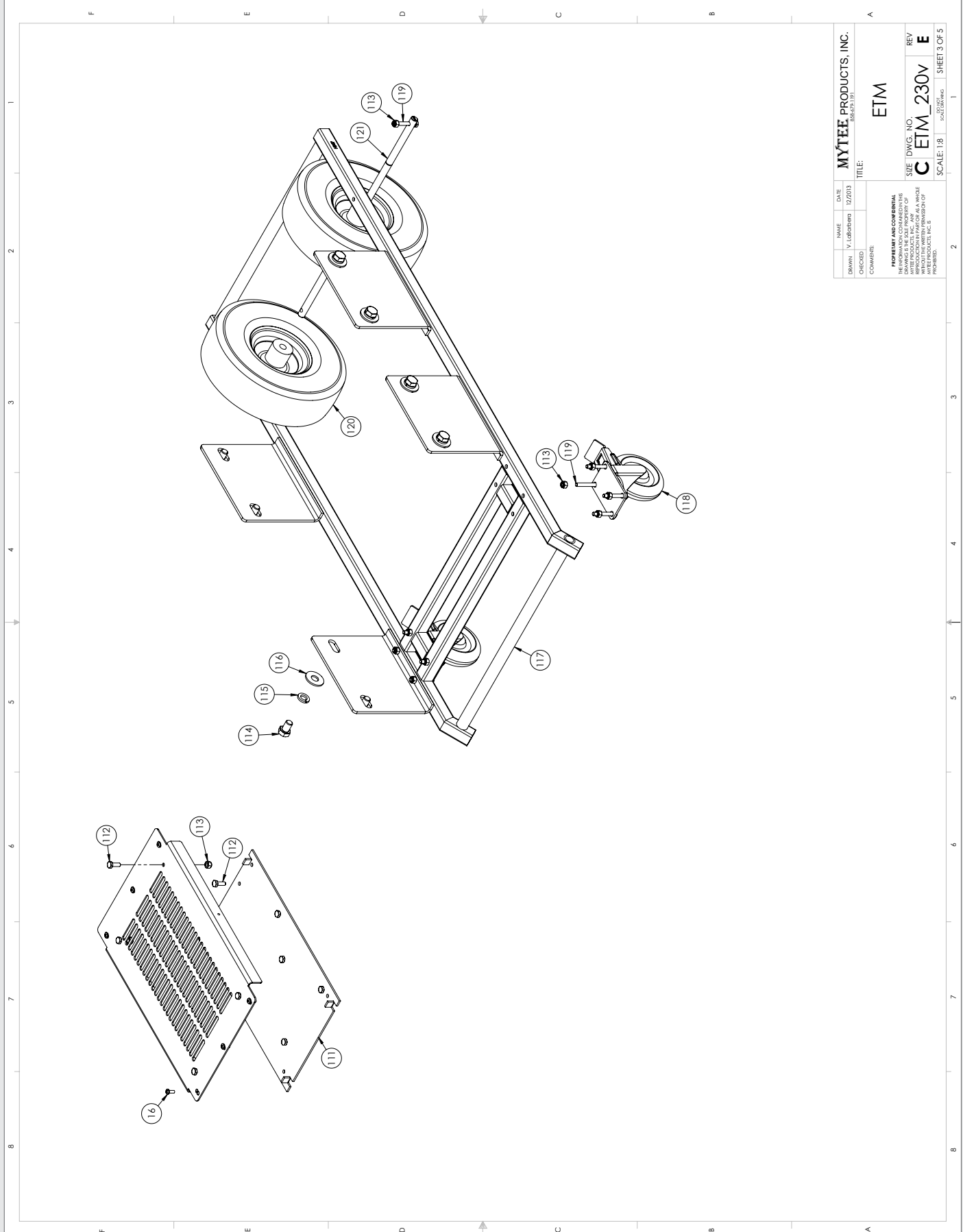

NAME	DATE	MYTEE PRODUCTS, INC.
DRAWN	12/2013	REVISED
CHECKED		TITLE:
COMMENTS:		
<p>PROPERTY AND CONFIDENTIALITY NOTICE: THIS DRAWING IS THE PROPERTY OF MYTEE PRODUCTS, INC. AND IS NOT TO BE REPRODUCED OR TRANSMITTED IN ANY FORM OR BY ANY MEANS, ELECTRONIC OR MECHANICAL, INCLUDING PHOTOCOPYING, RECORDING, OR BY ANY INFORMATION STORAGE AND RETRIEVAL SYSTEM, WITHOUT THE WRITTEN PERMISSION OF MYTEE PRODUCTS, INC.</p>		
SEE DWG. NO.	REV	
C	ETM_230V	E
SCALE: 1:8	SCALE: 1:8	SHEET 3 OF 5

Electric Truck Mount - 230 Volt

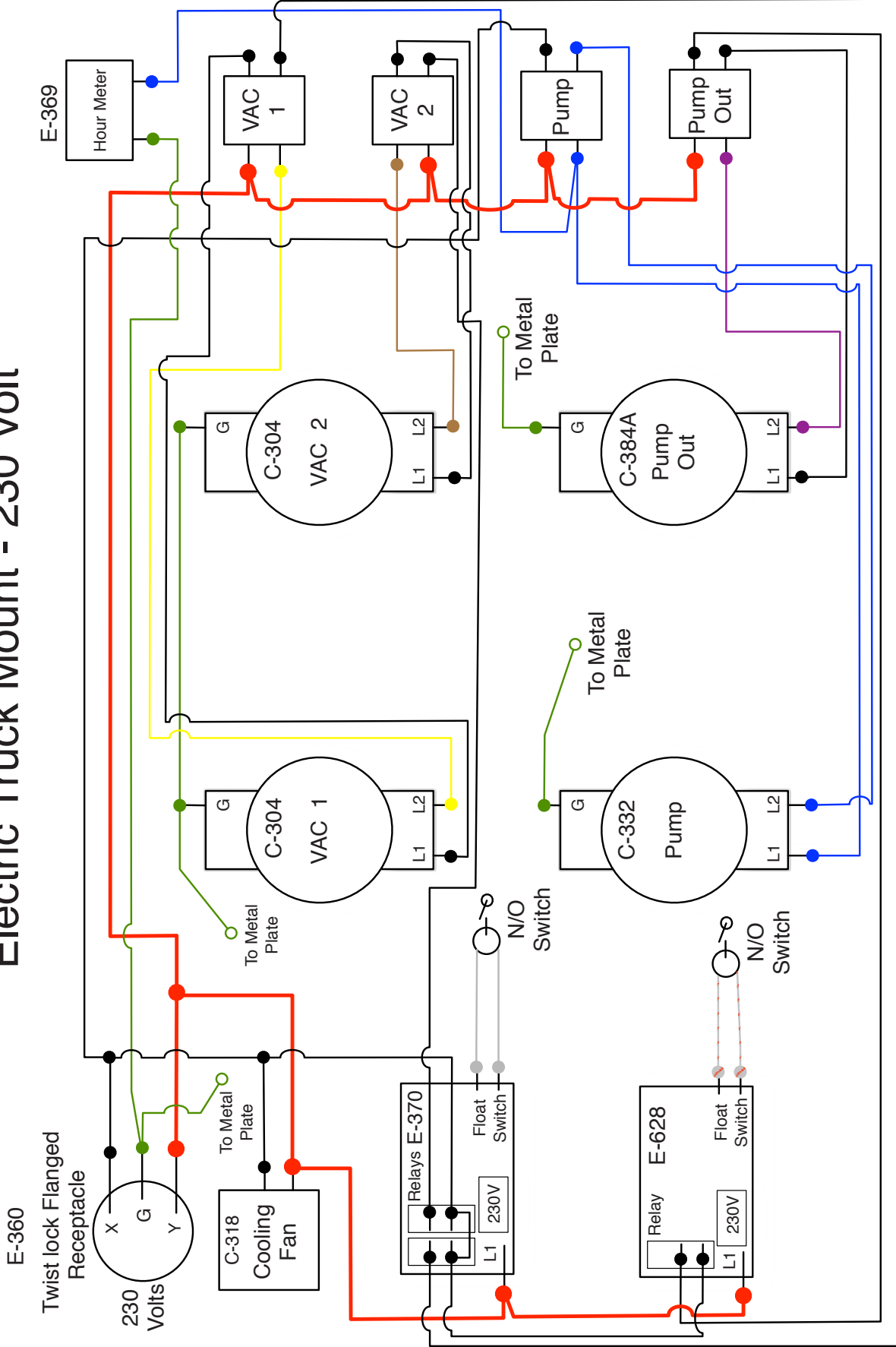

Red wires are 12 gauge

3/12/2013

Electric Truck Mount - 230 Volt

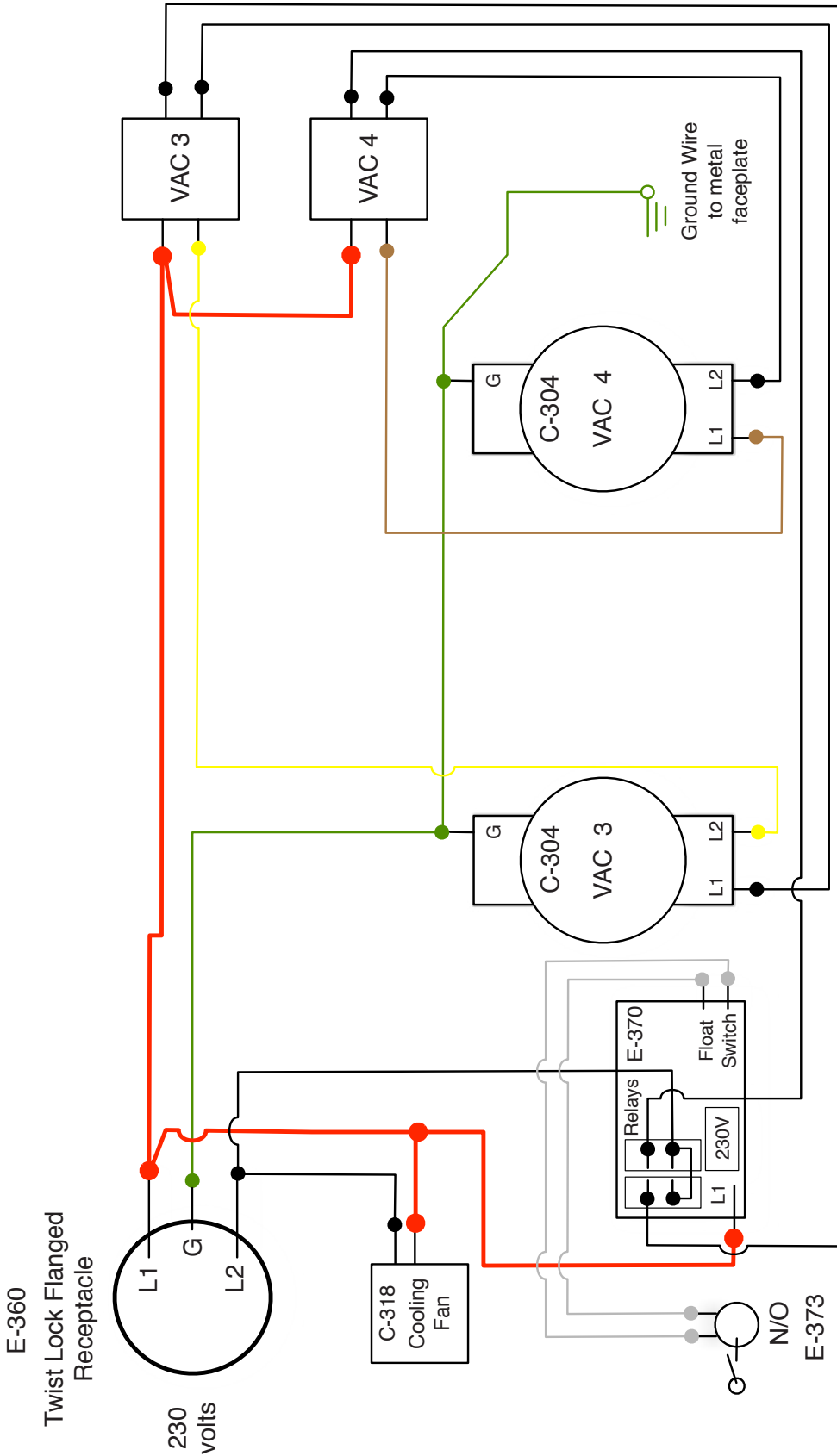

Red wires are 12 gauge

3/12/2013

Vacuum System

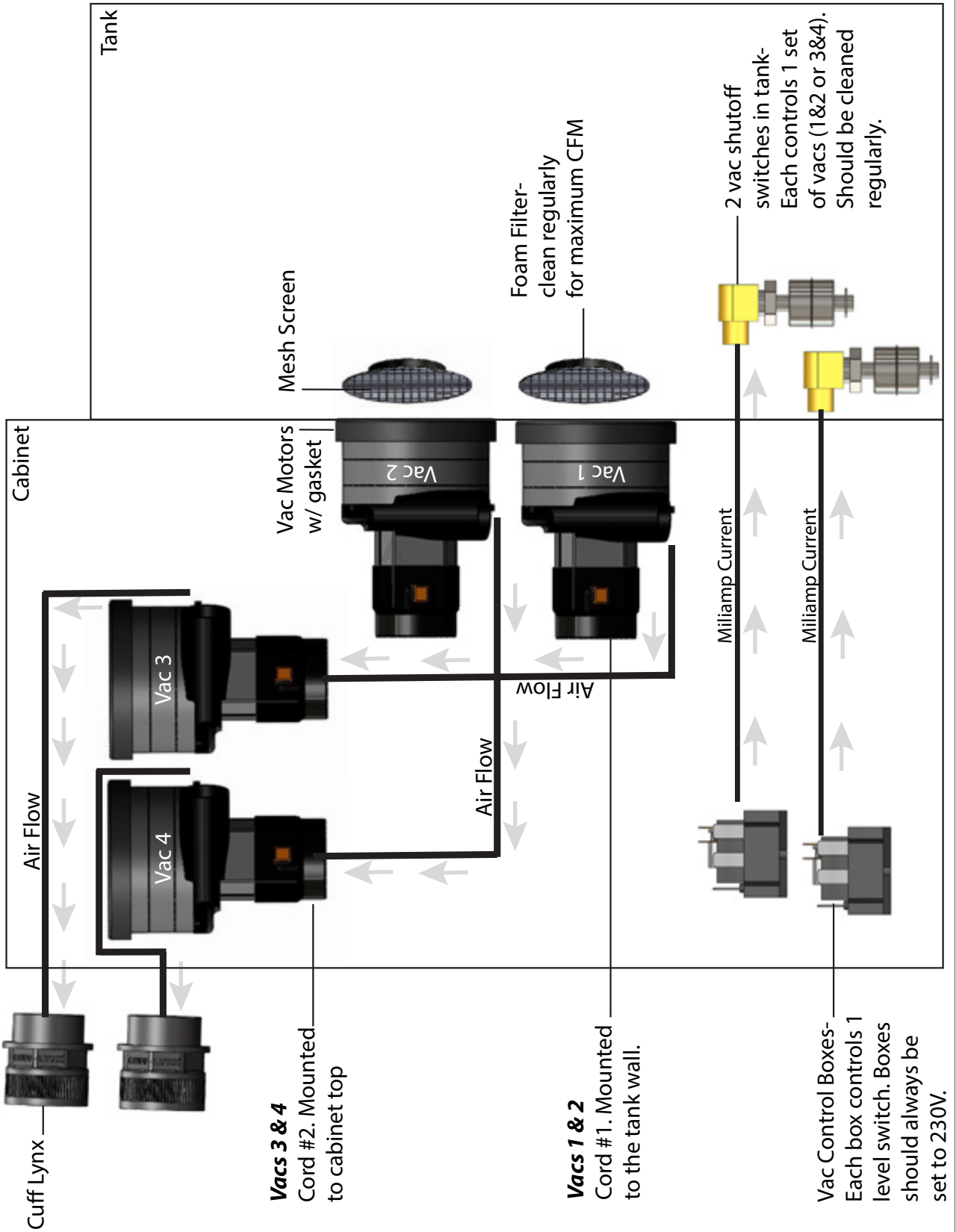

ESCAPE™ ETM HIGH PRESSURE PUMP SYSTEM

High Pressure Pump System

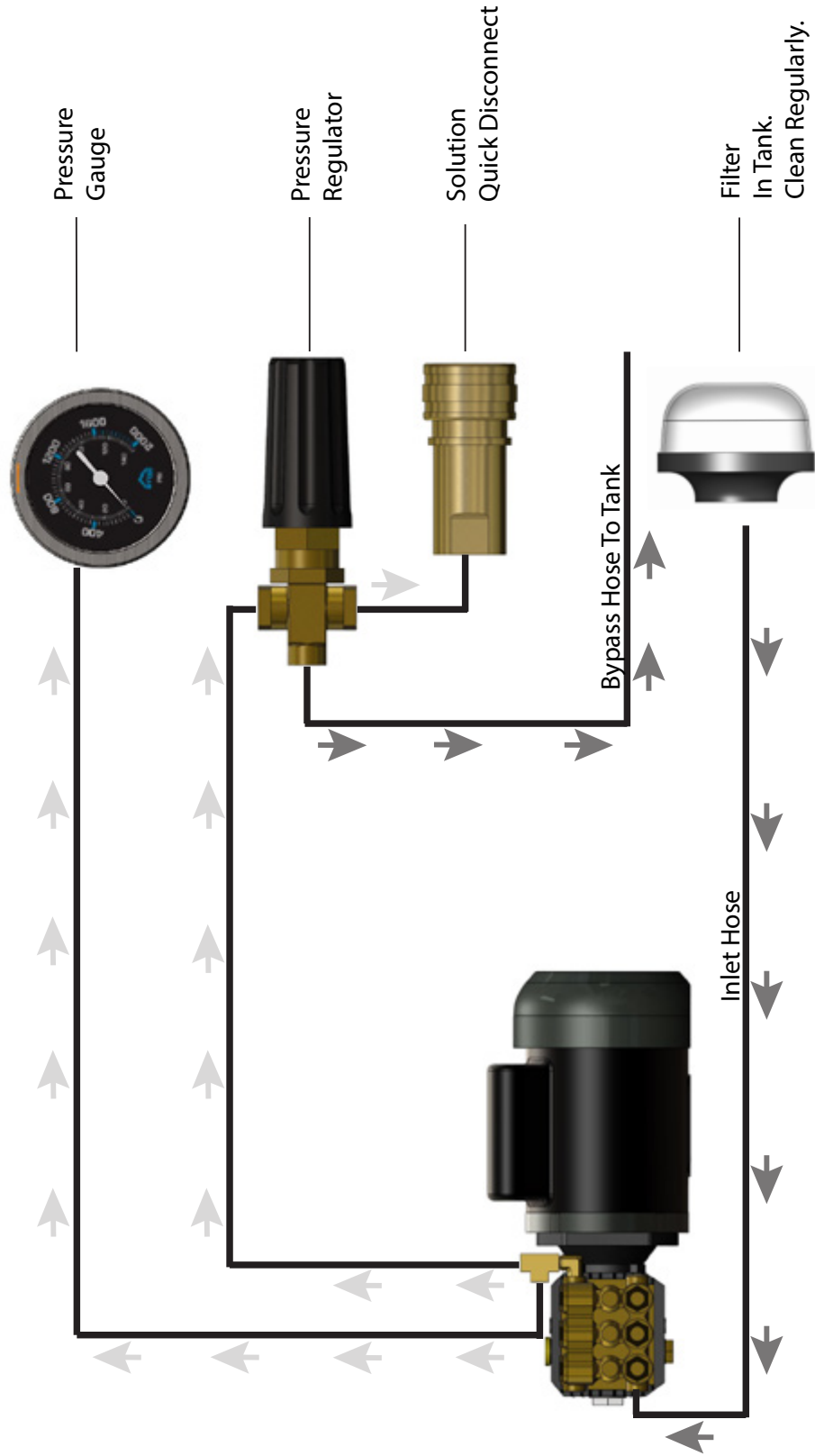

← = High Pressure

→ = Low Pressure

Auto-Fill & Chemical Injection System

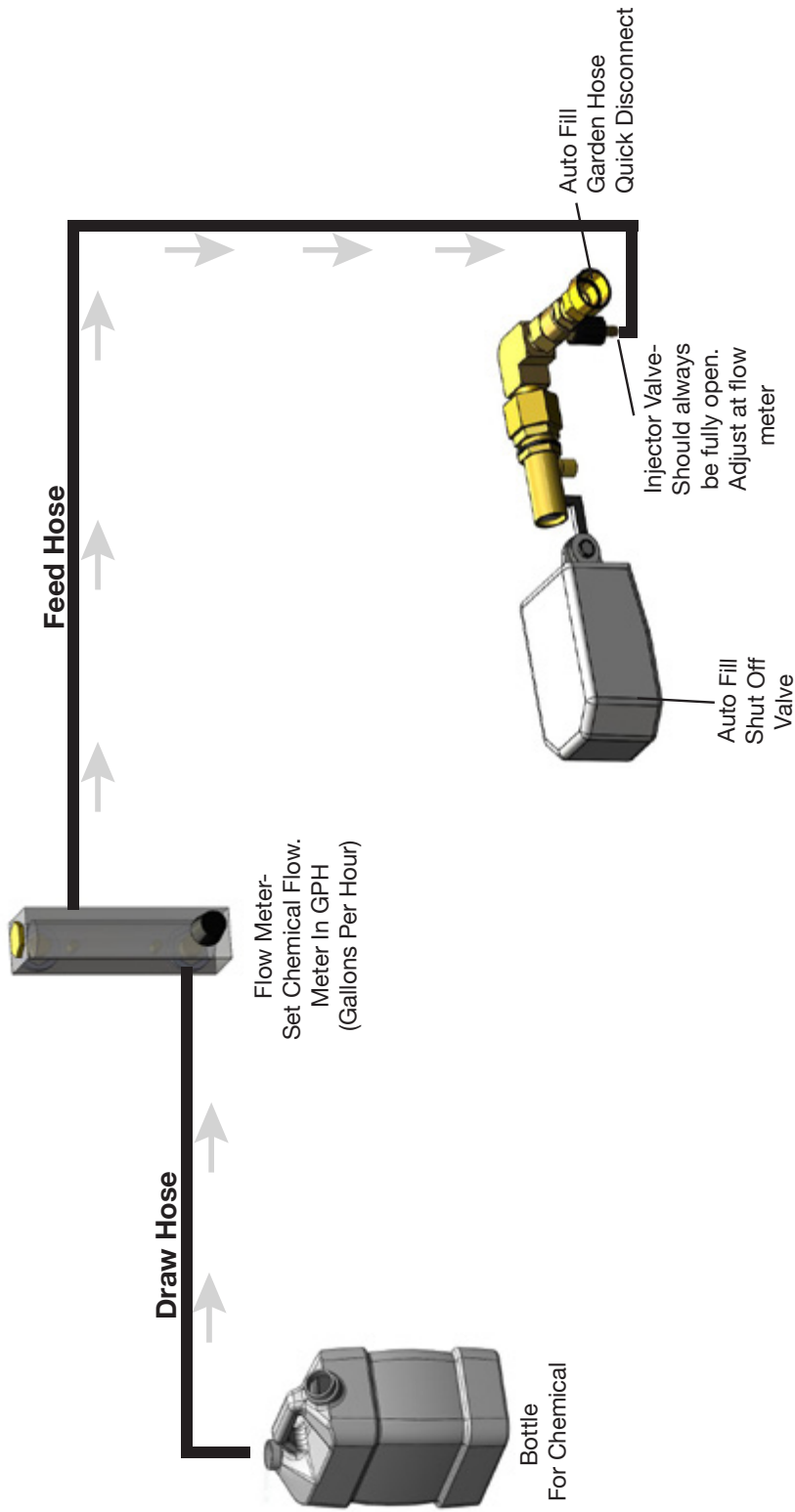

NOTES:

Since chemical injection is drawn at auto-fill, flow-meter will show "0" when tank is not filling.

To figure proper "GPH" for meter, determine the flow rate on the inbound water feed at auto fill. For example, if incoming water is 60 gallons per hour, and dilution for chemical is 10:1, then you would set the draw at "6" for a 60:6 ratio.

Auto Pump-Out System

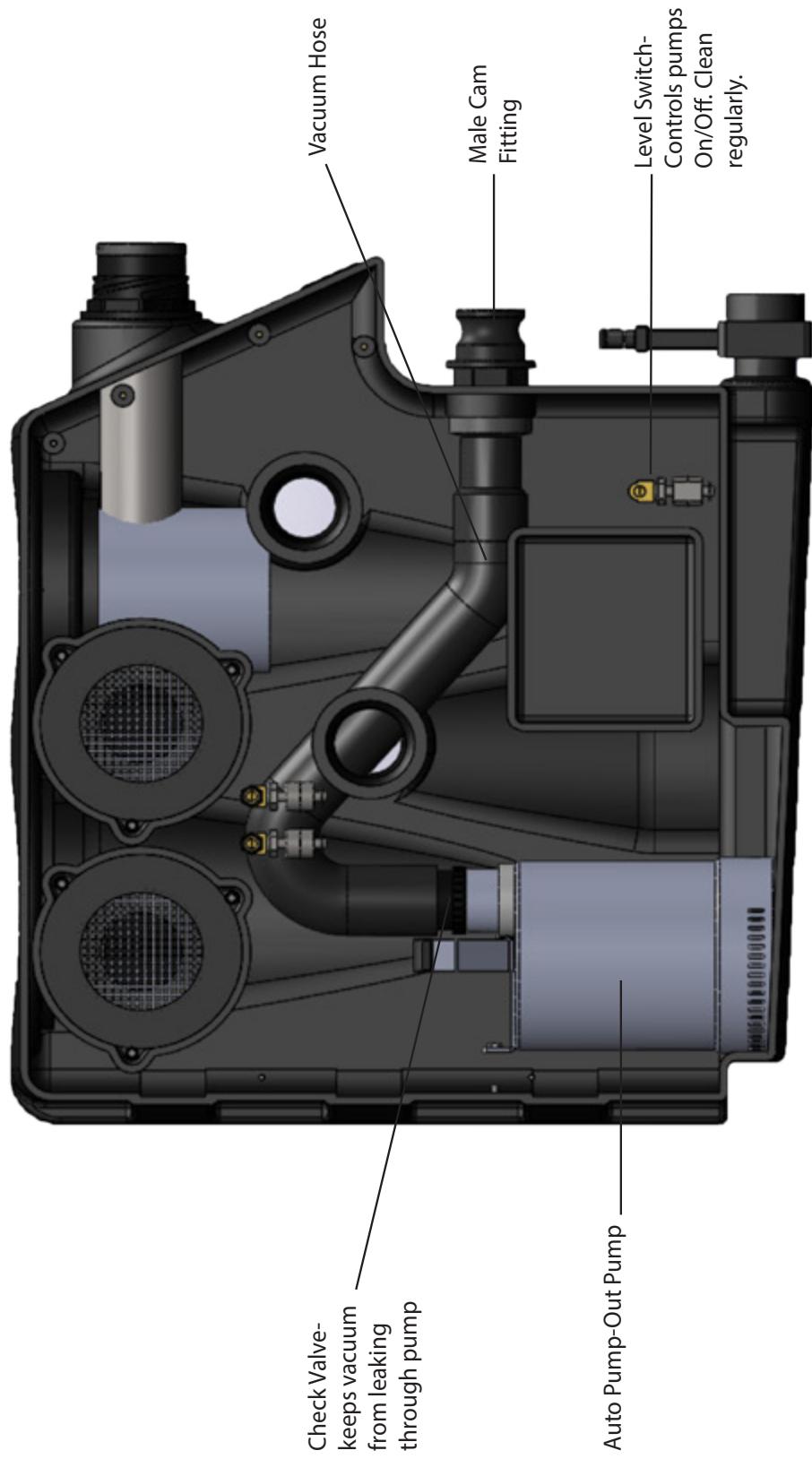

NOTES



Mytee Products Inc.
13655 Stowe Dr.
Poway, CA 92064
www.mytee.com
FX 858.679.7814

© 2016 Mytee Products Inc.
Printed in the U.S.A.