

A DIVISION OF TSI

AMERMAC™

www.buytsi.com
800.223.4540

REPAIR PARTS LIST 1200 TIRE TRUER UPPER PORTION 6-8-15

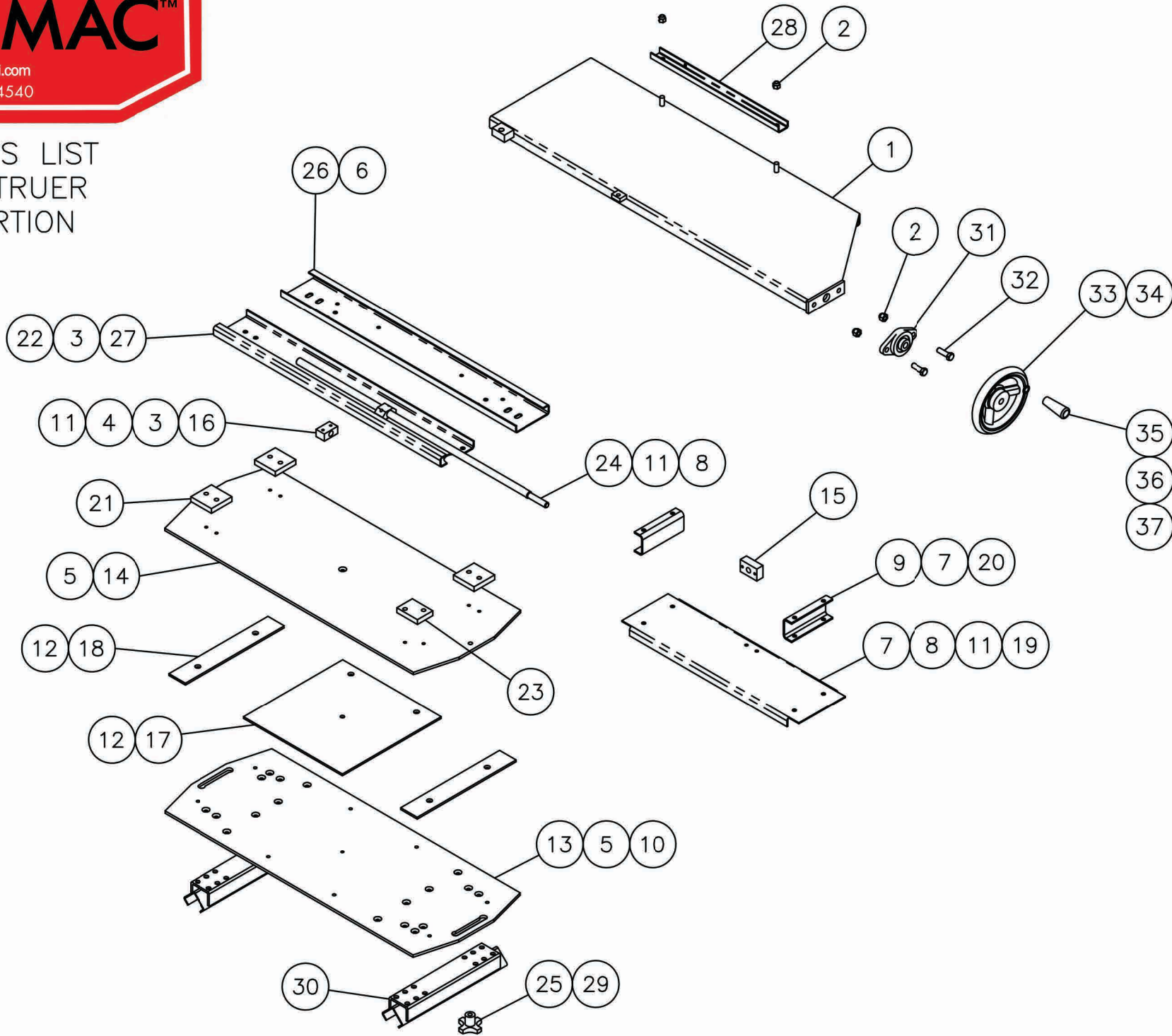

A DIVISION OF TSI

AMERMAC™

www.buytsi.com
800.223.4540

CABINET TRUERS – BASE REPAIR PARTS LIST (ALL CABINET TRUERS) PN 6410 SHEET 1 OF 3 6-1-15

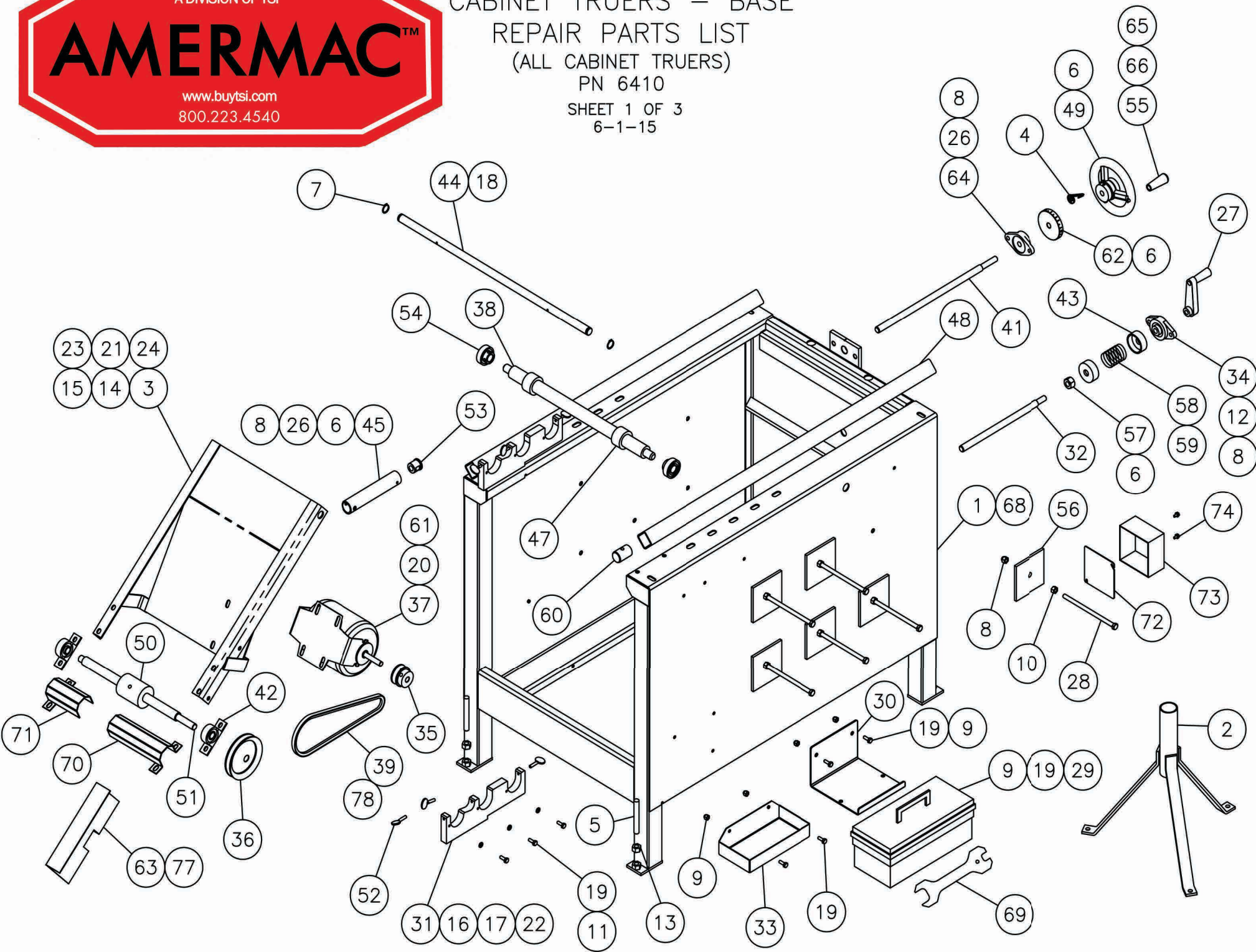



CABINET TRUERS - BASE

REPAIR PARTS BOM

Page 1 of 2

PN: 6410
 BEGINNING SERIAL NO.0000
 6/8/2015

PARTS LIST

ITEM	PART NO.	DESCRIPTION	QTY
1	6246	BASE WELDMENT	1
2	6281	TIRE STAND	1
3	6304	CRADLE, DRIVE ROLLER	1
4	6345	POINTER, GUIDE	1
5	218.028	SS SQ HD 1/2-13 X 2-1/2 PLATED	2
6	275.028	SHSS 1/4-20 X 3/8 CUP PT	4
7	196	SNAP RING 3/4" EXT	2
8	212	NUT 3/8-16 HEX NYLOK	11
9	226	NUT 1/4-20 NYLOK	6
10	398	NUT 3/8-16 HEX STD	6
11	445	WASH 1/4 FLAT	6
12	447	HHCS 3/8-16 X 1-1/4 PLATED	2
13	535	NUT HEX 1/2-13 STD	2
14	565	HHCS 5/16-18 X 1	4
15	566	NUT 5/16-18 NYLOK	8
16	700	WASHER 3/8 WROUGHT	8
17	719	HHCS 3/8-16 X 3/4	4
18	847	COTTER PIN 1/8 DIA X 1-1/4 LG	2
19	903	HHCS 1/4-20 X 3/4 GR2	12
20	1204	FL SP TERMINAL 8-10 STUD 16-14 WIRE	1
21	1318	WASHER 5/16 WROUGHT	8
22	1354	WASHER 3/8 LOCK	4
23	1630	WASHER 5/16 SPRING LOCK	8
24	1737	HHCS 5/16-18 X 3/4	4
25	3031	DECAL - WARNING	1
26	3500	HHCS 3/8-16 X 1-1/2 GR5	3
27	4954	CRANK W/HANDLE	1
28	10394	HHCS 3/8-16 X 7	6
29	11646	TOOL BOX	1
30	12036	TOOL BOX SUPPORT	1

PARTS LIST

ITEM	PART NO.	DESCRIPTION	QTY
31	15040	PILLOW BLOCK SADDLE	2
32	15050	SCREW, CRADLE	1
33	15051	TOOL BOX, SHORT	1
34	15052	FLANGE BEARING, 5/8"BORE	1
35	15057	PULLEY A-BELT 2.0 OD X 1/2"BORE	1
36	15058	PULLEY A-BELT 4-1/2 OD X 5/8"BORE	1
37	15067	MOTOR 1/3HP 115V 60Hz 1800rpm	1
38	15396	MANDREL 21" TRUER	1
39	15089	V-BELT, 4L TYPE 4L290	1
40	15090	WRENCH, MANDREL NUT	1
41	15140	SCREW, DRIVE	1
42	15143	BEARING, PILLOW BLOCK 5/8" BORE	2
43	15146	CUP, SPRING (on 15050 drive screw)	2
44	15148	ROD, CRADLE PIVOT	1
45	15155	TUBE, RAISING CRADLE	1
46	15160-1	DECAL - AMERMAC/TSI MAIN	1
47	15195	NUT, MANDREL	2
48	15212	MAIN RAIL	2
49	15216	WHEEL HANDLE 6"	1
50	15218	ROLLER, TIRE DRIVE	1
51	15219	SHAFT, TIRE DRIVE	1
52	15222	THUMB SCREW 1/4-20 X 1	6
53	15278	NUT, CRADLE, BRASS	1
54	15291	BEARING 1.85 OD X 3/4 ID - RB (CSB204-12)	2
55	15308	ROTATING HANDLE, KNOB	2
56	15312	RUBBER STOP	6
57	15315	NUT, JAM 5/8-8 ACME-2G L.H. DOUBLE	1
58	15316	SPRING 1.625 X 3" X .180 DIA WIRE	1
59	15317	SPRING 1.125 X 3" X .166 DIA WIRE	1
60	15323	RAIL MOUNT	4



REPAIR PARTS LIST
CUTTER HEAD

PN 6240
5-5-15
1 OF 4

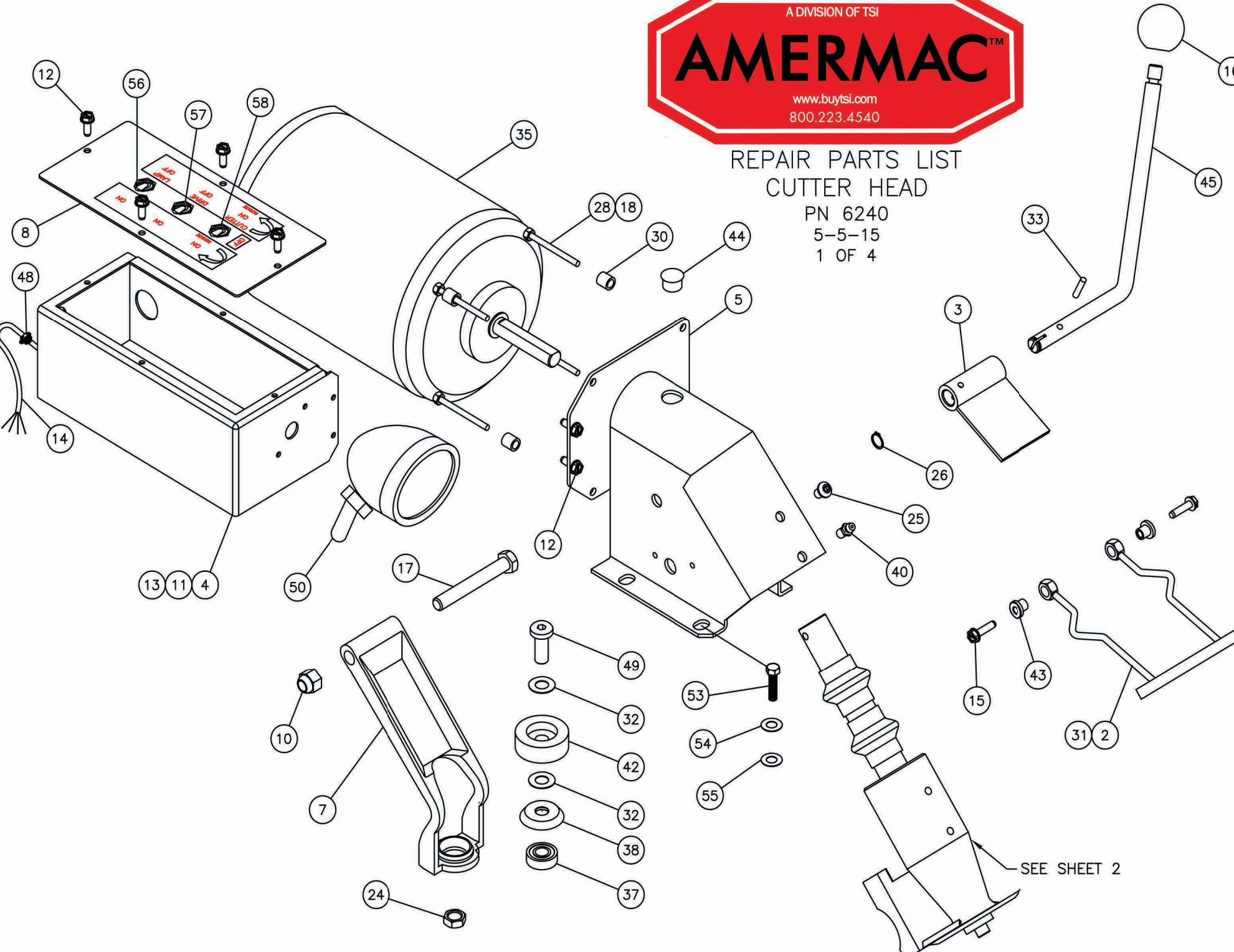

SEE SHEET 2



REPAIR PARTS LIST CUTTER HEAD PN 6240

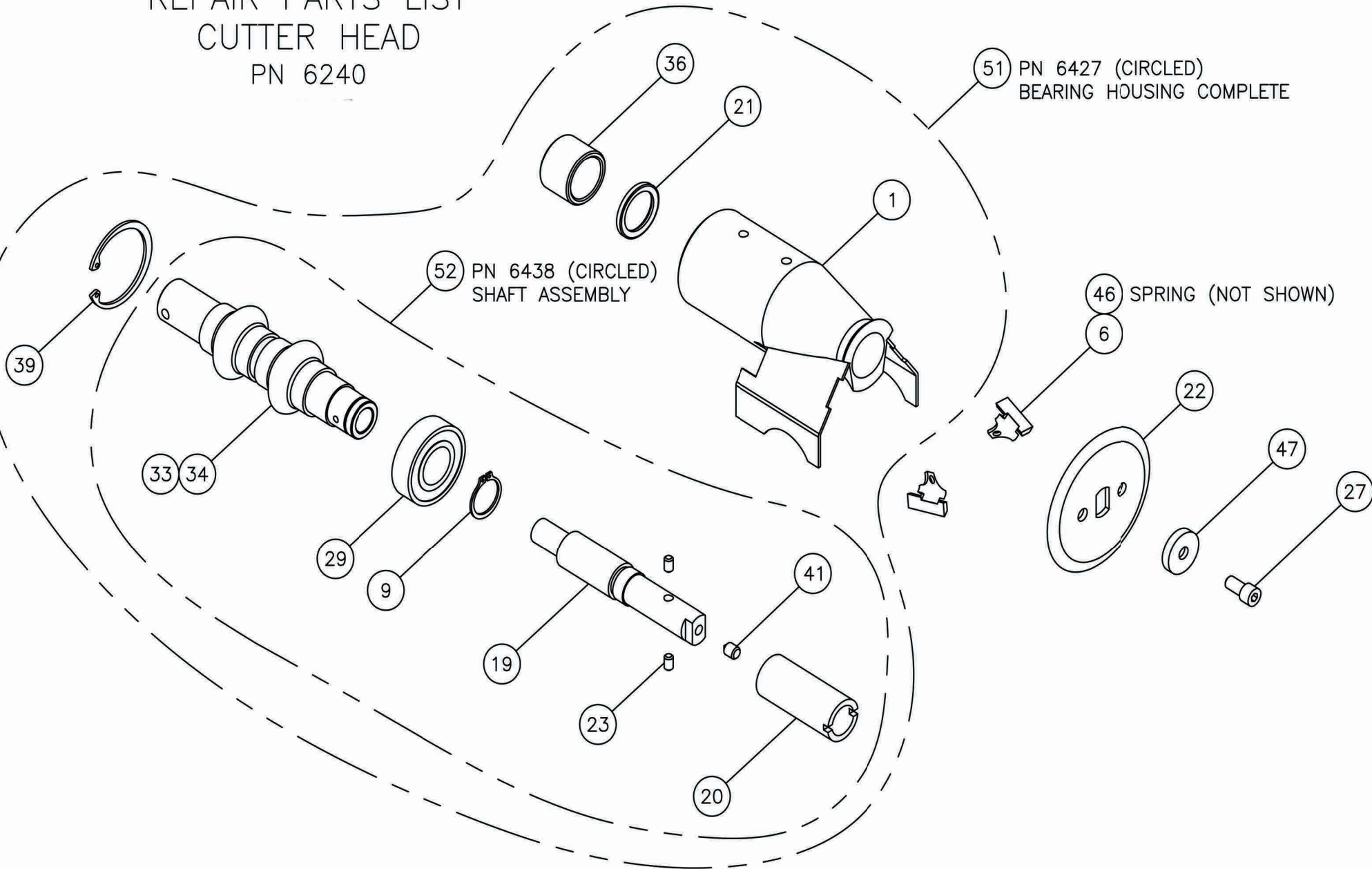



CUTTER HEAD

REPAIR PARTS BOM

Page 1 of 1

PN: 6240

BEGINNING SERIAL NO.0000

PARTS LIST

ITEM	PART NO.	DESCRIPTION	QTY
1	6241	BEARING HOUSING WELD	1
2	6242	BLADE GUARD	1
3	6248	PRESSURE LEVER	1
4	6254	ELEC BOX, WELD	1
5	6457	CUT HEAD, HOUSING WELD, 405	1
	6283	CUT HEAD, HOUSING WELD, 711,1100,1200	
6	6306	SPRING MOUNTED CARBIDE	2
7	6307	STONE CARRIAGE WELD	1
8	6308	CONTROL BOX WIRE DIAGRAM	1
9	196	SNAP RING 3/4 EXT	1
10	212	NUT 3/8-16 HEX NYLOK	1
11	15032	CONDUIT NIPPLE 1/2" RIGID	1
12	1055	WHCS #10-24 X 1/2 LG SELF TAP	6
13	1292	WIRE 16 GA TW STRANDED	AR
14	15333	CORD, ELECTRIC 16/4	AR
15	4569	HWHST #10-24 X 3/4 LG SELF TAP	2
16	4780	KNOB 1-5/16 DIA X 3/8-16 THD	1
17	10374	HHCS 3/8-16 X 3	1
18	10401	NUT #8-32 NYLOK	4
19	15000	SHAFT, CUTTER HEAD	1
20	15002	SLEEVE, ADJUSTMENT	1
21	15004	SEAL	1
22	15005	BLADE	1
23	15012	SLEEVE, LOCKING PIN	2
24	15021	JAM NUT 3/8-24	1
25	15022	BHCS 1/4-20 X 3/8	1
26	15023	SPRING-CLIP 7/16" DIA SHAFT X .035" THK	1
27	15025	SHCS 1/4-20 X 1/2	1
28	15029	MACH SCREW #8-32 X 7" LG	4
29	15030	BEARING .78 ID X 1.652 OD X .468 WIDE	1

PARTS LIST

ITEM	PART NO.	DESCRIPTION	QTY
30	15033	TUBE, SPACER MOTOR	4
31	15034	DECAL - SHARP BLADE	2
32	15043	PAPER WASHER	2
33	15044	SPRING PIN 5/32 DIA X 3/4	2
34	15066	UNIVERSAL JOINT MODIFIED	1
35	15067	MOTOR 1/3 HP 115V 60Hz 1800 rpm	1
36	15094	BUSHING, BRONZE	1
37	15138	BEARING, STONE	1
38	15211	STONE, DUST CAP	1
39	15223	SNAP RING 1-3/4 DIA X .062 THK	1
40	15224	ZERK 1L 1/4-28 STRAIGHT	1
41	15225	SHSS 1/4-20 X 3/8 POINTED	1
42	15226	STONE	1
43	15227	BUSHING, BLADE GUARD	1
44	15230	HOLE PLUG	1
45	15231	ARM, SHARPENER	1
46	15232	SPRING, CARBIDE HOLDER	2
47	15233	WASHER, BLADE MOUNTING	1
48	15241	STRAIN RELIEF - HEYCO 7P-2	1
49	15229	BOLT, GRINDING STONE	1
50	15297	LAMP ASSEMBLY, HALOGEN	1
51	6427	BEARING HOUSING COMPLETE	REF
52	6438	SHAFT ASSEMBLY	REF
53	368	HHCS 5/16-18 X 5/8	4
54	1630	SPRING LOCK WASHER	4
55	445	FLAT WROUGHT WASHER	4
56	15076	TOGGLE SWITCH #2 TERMINAL	1
57	15075	TOGGLE SWITCH #4 TERMINAL	1
58	15074	TOGGLE SWITCH #12 TERMINAL	1

ELEC PARTS FOR ASSY		
TOGGLE	TERM CONN	QTY
15074	15217	5
	15294	5
	15295	15
	15296	3
15075	15217	2
	15294	2
	15295	4
15076	15295	2

USE GASOLINE RESISTANT
UL APPROVED 16 AWG
WIRE AS REQUIRED.

ELEC PARTS TO CONNECT TO
LAMP AND MOTOR INCLUDED.

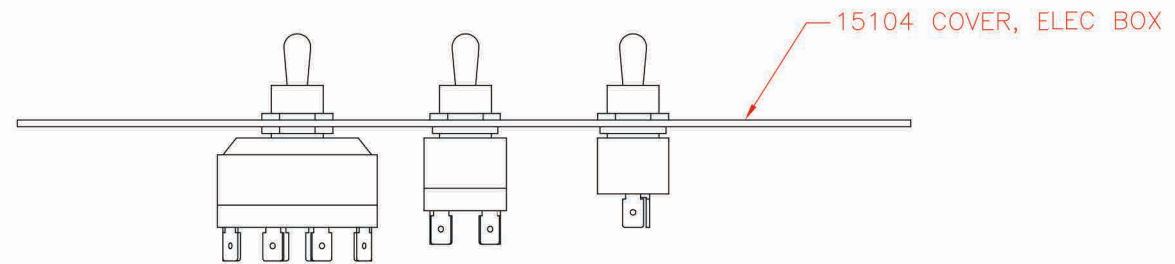
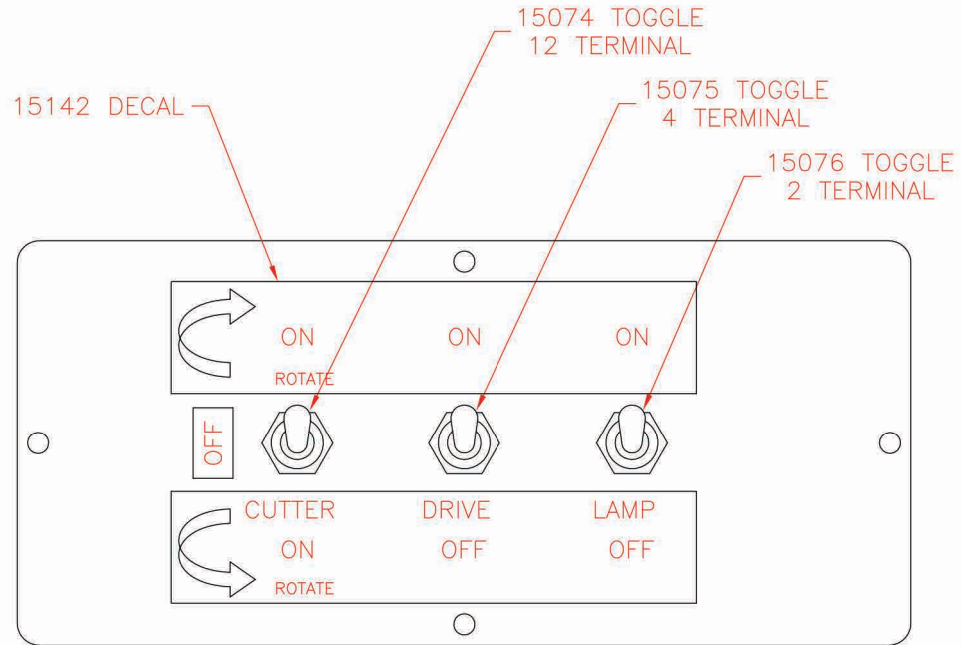

1. REMOVE ALL BURRS & SHARP EDGES.

NOTE:

THE SUBJECT OF THIS DRAWING IS SUBMITTED IN CONFIDENCE AND IT AND THE DRAWING WILL AND SHALL REMAIN THE PROPERTY OF TIRE SERVICE EQUIPMENT INC., AND ARE NOT TO BE USED WITHOUT ITS WRITTEN PERMISSION AND APPROVAL. © 2010	MAT'L: SEE DRAWING		DESIGNER: M. REDISKE	SCALE: N/A	REV	DESCRIPTION	DATE
	TOLERANCE UNLESS NOTED: DECIMALS ±.010 FRACTIONS ±1/32 ANGLES ±1/2°		DR. BY: M. REDISKE	DATE: 05/24/10	USED ON: 711		SHEET: 1 OF 2
			CH. BY:	INT:	PART NAME: CONTROL BOX WIRE DIAGRAM DWG NO. 6308		QTY PER UNIT: NA



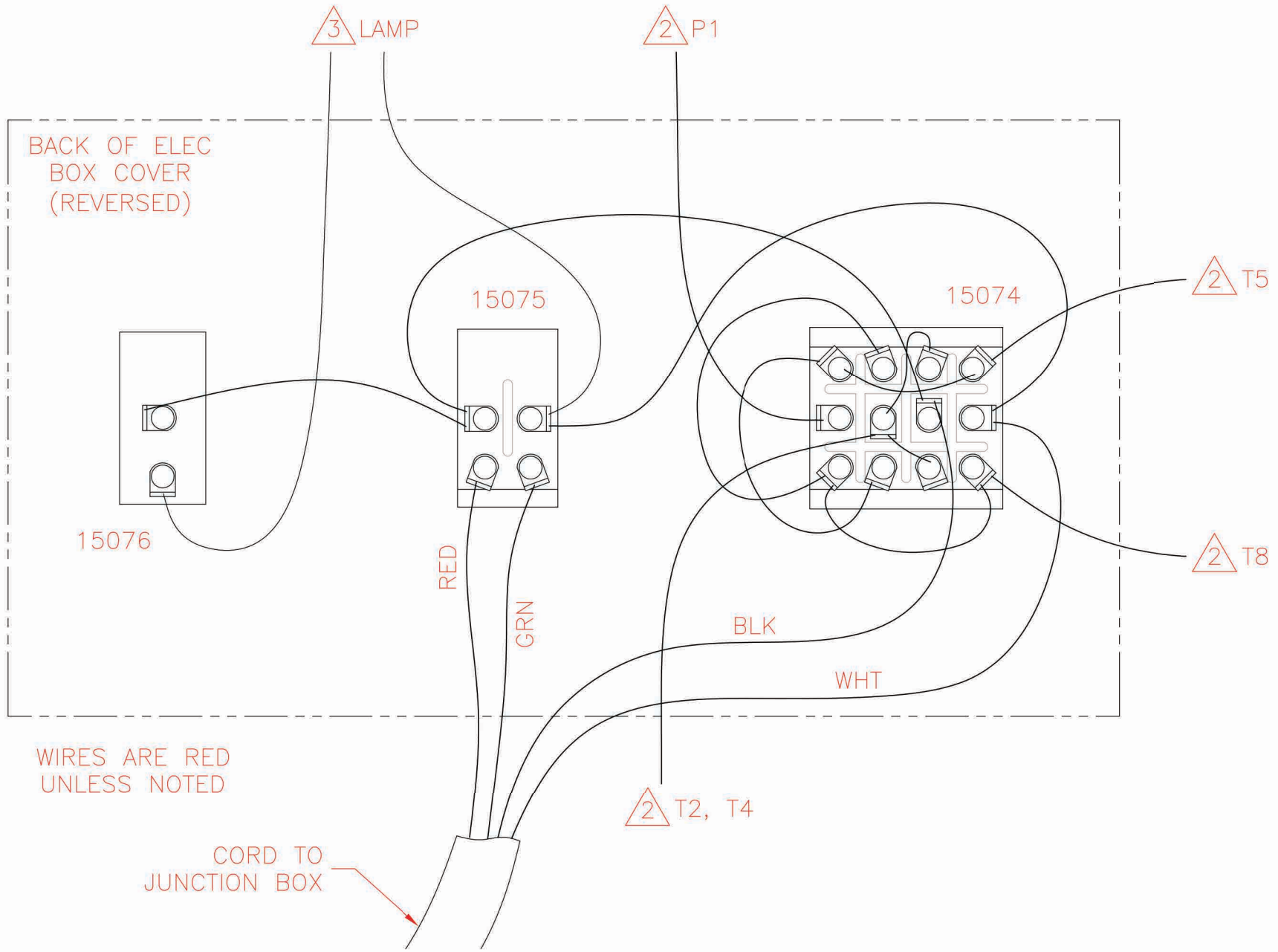

BACK OF ELEC BOX COVER (REVERSED)

15075

15074

15076

RED

GRN

BLK

WHT

WIRES ARE RED UNLESS NOTED

CORD TO JUNCTION BOX

- △3 LOCATION TO CONNECT LAMP.
- △2 WIRES P1, T2, T4, T5 & T8 REFER TO A LEESON MOTOR SOURCE. THE SAME LEADS CAN BE USED ON A MARATHON MOTOR SOURCE.

NOTE: 1. REMOVE ALL BURRS & SHARP EDGES.

THE SUBJECT OF THIS DRAWING IS SUBMITTED IN CONFIDENCE AND IT AND THE DRAWING WILL AND SHALL REMAIN THE PROPERTY OF TIRE SERVICE EQUIPMENT INC., AND ARE NOT TO BE USED WITHOUT ITS WRITTEN PERMISSION AND APPROVAL. © 2010

MATL: SEE DRAWING

TOLERANCE UNLESS NOTED:
 DECIMALS ±.010
 FRACTIONS ±1/32
 ANGLES ±1/2°

DESIGNER: M. REDISKE
 DR. BY: M. REDISKE
 CH. BY:

SCALE: N/A
 DATE: 05/24/10
 INT:



REV	DESCRIPTION	DATE
USED ON: 711		SHEET: 2 OF 2
PART NAME: CONTROL BOX WIRE DIAGRAM		QTY PER UNIT: NA
C	DWG NO. 6308	